



# Eddy Probe Systems

**Probes and Drivers**

**Mounting Devices**

**Housings**

**Pressure Feedthroughs**

**Calibrators and Simulators**

**Accessories**

# Eddy Probe Systems Catalog

## Table of Contents

<b>Introduction/Selection</b>	<b>1</b>
Introduction .....	1
Shaft Relative Motion .....	1
Eddy Probe Systems .....	1
Frequency Considerations .....	1
The Versatile Eddy Probe .....	2
How It Works .....	2
Selecting An Eddy Probe System .....	3
Some Eddy Probe Options .....	3
<b>RYTON® Based Eddy Current Transducers</b>	<b>5</b>
CMSS 65/CMSS 665 Series – 5mm Eddy Probe System .....	5
CMSS 68/CMSS 668 Series – 8mm Eddy Probe System .....	8
CMSS 62/CMSS 620 Series – 19mm Eddy Probe System .....	12
<b>Eddy Current Probe Installation Accessories</b>	<b>14</b>
CMSS 920 High Pressure Feedthrough .....	14
CMSS 911 Probe Holder With Housing .....	15
CMSS 911 Dual Sensor Holder With Housing .....	15
CMSS 904 Probe Holder .....	17
CMSS 912 Dual Axial Probe Adapter .....	17
CMSS 903 Series – Mounting Brackets .....	18
CMSS 30112000 Series – Cable Packing Gland Assembly .....	19
CMSS 30837800 1/2" or 3/4" NPT Probe Adapter .....	19
<b>Driver Housings</b>	<b>20</b>
Explosion-Proof Housings For DIN-Rail Mount Drivers .....	20
Weatherproof Housings .....	21
<b>CMSS 601 Static Calibrator</b>	<b>23</b>
<b>CMSS 748-3 Probe Gapper</b>	<b>24</b>
<b>Typical Eddy Probe Arrangement Plans</b>	<b>25</b>
Turbine .....	25
Compressor .....	25
Electric Motor .....	26
Pump .....	26
Gear Box (Double Helical Gear) .....	27
<b>Bearing Housing Mounting</b>	<b>28</b>
<b>Axial Probe Installation</b>	<b>29</b>
<b>Outline Dimension Drawings</b>	<b>30</b>
5mm and 8mm Eddy Probe Outline Dimension Drawing .....	30
5mm and 8mm Eddy Probe Driver Outline Dimension Drawing .....	31
CMSS 958 Extension Cable Outline Dimension Drawing .....	32
<b>Hazardous Area Information</b>	<b>33</b>
Area General Information .....	33
Agency Approvals .....	33
Intrinsic Safety (I-S) Barriers For Use With CMSS 65 and CMSS 68 Series Eddy Probe Systems .....	34

# Eddy Probe Systems Catalog

## Table of Contents

<b>Hazardous Location Information</b>	<b>35</b>
Classes and Divisions .....	35
Electrical Sources of Ignition .....	35
Hazardous Locations and the National Electrical Code .....	35
Hazardous Location Equipment .....	36
Hazardous Location Equipment Applications .....	36
Chemical By Groups .....	37
Groups A, B, C, D, E, F, and G .....	37
Hazardous Locations Cross Reference .....	38
<b>Industry Reference Information</b>	<b>38</b>
Industry Reference Information (What's In A Rating?) .....	38
Comparison of Specific Non-Hazardous Applications (Outdoor Locations) .....	38
Enclosures For Non-Hazardous Locations .....	39
Comparison of Specific Non-Hazardous Applications (Indoor Locations) .....	39
International Standards' IP Protection Classification .....	40
NEMA, UL, CSA, Versus IEC Enclosure Type Cross-Reference (Approximate) .....	41
Sources of Standards .....	41
<b>Glossary</b>	<b>42</b>

## Introduction

Effective protection of rotating machinery requires that the proper type of measurement be performed. The most suitable type of transducer may then be defined. Finally, specific application circumstances (frequencies of interest, operating temperatures, mounting requirements) are considered to select the optimum transducer. The chart at right provides general guidelines for determining the most effective type of measurement.

## Shaft Relative Motion

Shaft relative motion is the radial vibration of the shaft journal relative to the bearing. This method of vibration measurement is preferred for journal bearings since it directly relates to permissible clearances. In machines with relatively light rotors and stiff heavy casings (turbines and compressors) almost all of the shaft's vibration energy is dissipated as displacement (exhibit low transmissibility) which can only be measured as shaft relative motion.

An Eddy Probe, mounted to, or through the bearing, observes the shaft to provide this measurement. An additional Eddy Probe is often installed 90° from the first, in an orthogonal arrangement, to increase monitoring and diagnostic capabilities (voting logic and shaft orbit display).

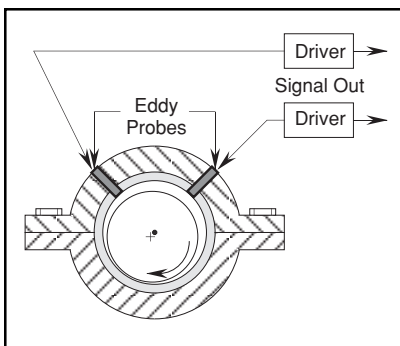

## Eddy Probe Systems

The Eddy Probe is used to measure radial or axial shaft motion. It is mounted through or to the side of a bearing cap and observes the shaft's movement relative to its mounting position. An Eddy Probe System comprises a Probe, a Driver (oscillator demodulator), and an Extension Cable.

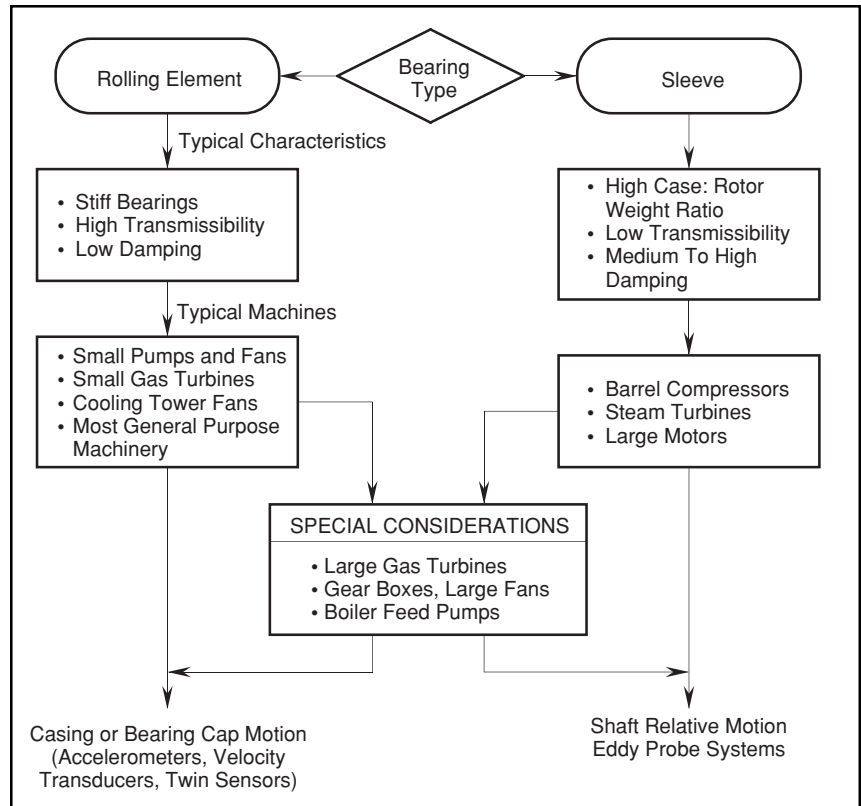

Eddy Probe Systems have excellent frequency response. They have no lower frequency limit and are used to measure shaft axial position as well as vibration.

While Eddy Probe Systems offer excellent high frequency response, displacement at typical blading and gear mesh frequencies is quite small (an accelerometer may be used to augment the Eddy Probe System when high frequencies are a concern).

## Frequency Considerations

Shaft relative measurements always use Eddy Probes and are indicated in terms of displacement. Bearing cap or casing measurements, however, may use accelerometers or velocity transducers, either of which may be conditioned to indicate in terms of acceleration, velocity, or displacement.

The frequency range of interest and the desired measurement terms are critical factors in transducer selection. Vibration presented in terms of velocity is generally accepted as a valid indication of destructive energy across the entire range of frequencies,

whereas displacement and acceleration levels must always be evaluated considering the frequency content.

High frequency measurements (rolling bearings, gear mesh, and blade passage) are best made using an accelerometer and presented in terms of acceleration, which is typically strong at these frequencies.

Low frequency (< 15 Hz) bearing cap vibrations need special treatment. The frequency response of most reasonably priced Velocity Transducers starts dropping off between 10 Hz and 20 Hz and, although Accelerometers commonly respond down to 3 Hz, acceleration is very weak at low frequencies. The best solution is to integrate the Accelerometer's signal to read out in terms of velocity. Double integration to displacement would provide the strongest signal but, except in very special cases, it is inadvisable because of significant low frequency instability associated with the integration process.

- NOTE -

*Eddy Probe, Displacement Probe and Proximity Probe are all synonyms for the same or similar products manufactured and supplied by various companies.*

## The Versatile Eddy Probe



The Eddy Probe System is a field proven method for reliably detecting various machine displacement parameters. The Probe's simplicity and rugged design enables it to withstand the temperatures and chemicals typically encountered in the harsh machine environment.

### How It Works

The tip of the Eddy Probe contains an encapsulated wire coil which radiates the Driver's high frequency signal into the observed target as a magnetic field. The Driver outputs a dc voltage representing the field strength. As a conductive surface approaches the coil, eddy currents are generated on the target surface, which decreases the field's strength resulting in a decrease of the Driver's dc output.

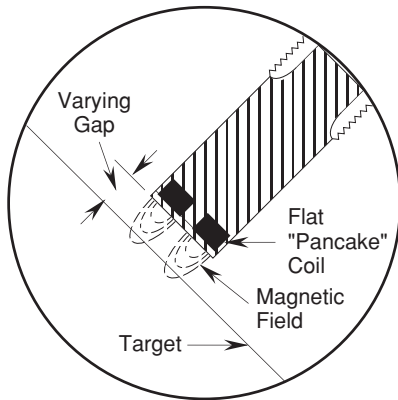

*Eddy Probe Tip.*

The Driver linearizes and normalizes its output to a specific sensitivity (usually 200 mV/mil) throughout its working range. The signal's dc bias, representing the average probe gap, and its AC component, profiling surface movement and irregularities, is readily used in many applications, some which are shown in the following diagrams.

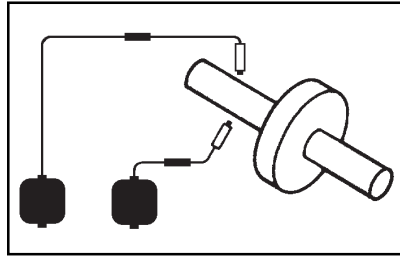

*Radial Motion of Rotating Shafts.*

Shaft vibration is represented as a varying dc voltage which may be used for monitoring, balancing, or analysis. Using two Probes separated by 90°, shaft orbit may be derived and X-Y voting logic monitoring may be used.

**Companion Unit:** *CMMA 864 Vibration Monitor*

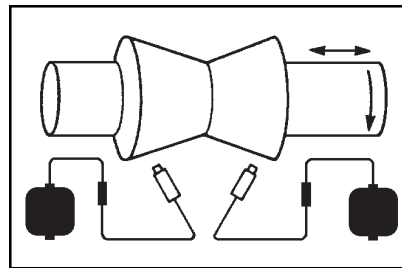

*Differential Expansion.*

The Eddy Probe is rigidly mounted to the machine case and observes a ramped section of the shaft or a perpendicular shaft collar. The dc output voltage represents the axial shaft position and varies as the shaft and/or case experience thermal movement. Differential expansion monitoring confirms acceptable rotor/case growth rates.

**Companion Unit:** *CMMA 833 TSI/ Position Monitor*

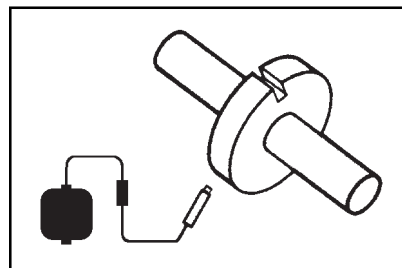

*Key Phasor/Speed.*

As the Eddy Probe observes the passage of a hole or keyway on a shaft or collar, the Driver outputs a voltage pulse. This pulse may be used to generate a speed display or, along with vibration data, it can also be used to perform dynamic balancing. Multiple events per revolution (such as a gear) may also be observed by the Eddy Probe for speed determination.

**Companion Unit:** *CMMA 881 Speed and Phase Monitor*

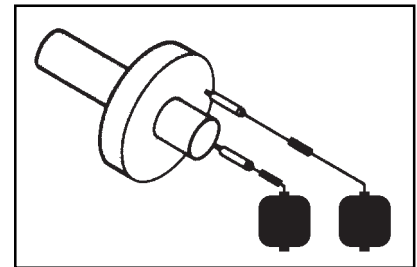

*Axial (Thrust) Position.*

Shaft axial (thrust) position is represented by the average dc voltage and is normally used for monitoring. Two Probes are recommended to permit voting protection (especially on systems armed for automatic shutdown).

**Companion Unit:** *CMMA 864 Position Monitor*

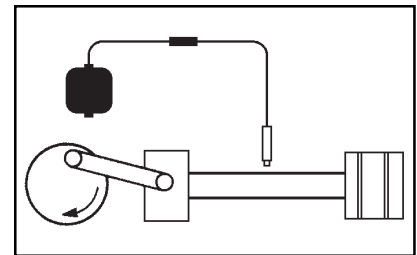

*Rod Drop.*

As the piston rings, rider rings, and cylinder liners wear, allowing the rod to gradually drop, the probe gap widens. The Driver's dc voltage output may be used to determine when rings should be turned/replaced before damage to the piston occurs.

**Companion Unit:** *CMMA 833 TSI/ Position Monitor*



## Selecting An Eddy Probe System

A wide variety of SKF systems are offered to meet the requirements of virtually any application. Probe range is limited largely by the probe's diameter. The standard SKF probe diameters are 5mm (CMSS 65), 8mm (CMSS 68), and 19mm (CMSS 62).

The following should be considered when selecting a system:

### RANGE

Gap over which the system must accurately operate.

### SENSITIVITY

Must be compatible with monitors or other companion instruments.

### SYSTEM LENGTH

The physical length of the systems is approximate to the electrical length. Excess cable in certain installations is typically coiled and tied with no harmful effects.

### PROBE CASE

The size of the probe mounting case may be a factor in some installations (several case options are available indicated under ordering information).

Standard SKF Eddy Probe Systems.

System	Usable Range	Sensitivity	System Length	Standard Case	Comments
CMSS 65/CMSS 665	80 Mils	200 mV/Mil	5 Meters	1/4-28	Standard System
CMSS 68/CMSS 668	90 Mils	200 mV/Mil	5 Meters	3/8-24	Meets Intent Of API 670
CMSS 68/CMSS 668-1	90 Mils	200 mV/Mil	10 Meters	3/8-24	Long System Length
CMSS 68/CMSS 668-2	90 Mils	200 mV/Mil	15 Meters	3/8-24	Long System Length
CMSS 62/CMSS 620-2	60-300 Mils	50 mV/Mil	10.8 Meters	1"-12 UNF	Long Range
CMSS 68/CMSS 668-5	15-160 Mils	100 mV/Mil	10 Meters	3/8-24	Long Range

## Some Eddy Probe Options

### ARMOR

A flexible stainless steel jacket protects the cable. Recommended when the cable is not protected by conduit. Available on Probe Cables and Extension Cables. Not compatible with Cable Packing Glands.

### CERTIFICATION

Approved Probes and Drivers can be supplied with either nonincendive or intrinsic safety approvals. Nonincendive products are supplied with FM (Factory Mutual) certification tags attached. Intrinsically safe products are supplied with triple agency approval certification tags attached (EECS [BASEEFA], FM [Factory Mutual Systems] and CSA).

### CE Mark

Beginning January 1996, European Community requires equipment sold in their area to be a CE marked product. Because sensors have an active component such as the integrated circuit amplifier, the sensor should have the CE mark.

## A Word About . . .

### PROBE TIPS

SKF uses RYTON® for Eddy Probe tips because it is simply the best material for the job. RYTON has high dimensional stability reducing probe

coil shape variations with temperature and humidity and maintaining system accuracy, linearity, and resolution. RYTON is a "super plastic" that has no known solvent below +400°F (+205°C) and therefore highly resistant to the acids, bases and solvents handled by process machinery.

### INSTALLATION

Major considerations include temperatures, pressures, and mechanical stress to which the Probe, Driver, and cables are subjected. It is essential that the Probe be rigidly mounted, yet easily adjusted (SKF mounting accessories are ideal for this). If long cable runs between the Driver and Monitor are required, consult the table to the right to determine the maximum recommended wire length (use 3-conductor shielded wire).

### TARGET MATERIAL

Standard systems are calibrated to observe 4140 steel. As recommended by API Standard 670, Probe calibration should be verified on a target with the same electrical characteristics as the shaft. The SKF CMSS 601 Static Calibrator and the Driver trim control, permit verification and convenient field calibration within a ± 5% range on the shaft itself. Response is dependent upon the conductance of the target material, as illustrated on the chart. Drivers may be special ordered for calibrated response to different metal types. Customers will be requested to provide samples of the metal types.

### RUNOUT

Because the Eddy Probe works on the principle of conductivity, shaft irregularities (flat spots, scratches, plating, hardness variations, carbon inclusions, magnetized regions, etc.) may produce false vibration signals. API Standard 670 recommends combined total electrical and mechanical runout does not exceed 0.25 mils maximum. Some irregularities, such as plated shafts, cannot be reduced to an acceptable level with traditional methods (peening, knurling, etc.).

Wire Size (AWG)	Distance (Maximum)
22	500 Feet (150 meters)
20	1,000 Feet (300 meters)
18	2,000 Feet (600 meters)
16	3,000 Feet (900 meters)

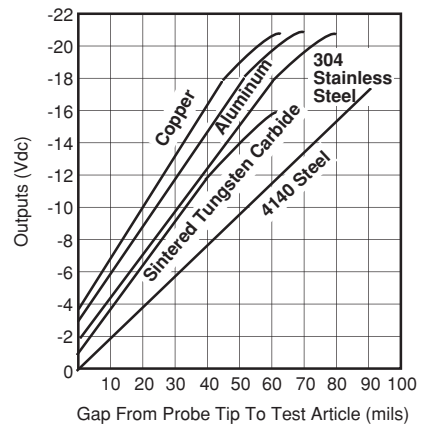

System response varies with the target material.

## Selecting An Eddy Probe System

### INTRINSIC SAFETY

SKF Monitors provide current limited power to Eddy Probe Systems which meet safety requirements of most applications. However, if intrinsic safety barriers (Zener barriers) will be used, consult the local sales representative to ensure range, linearity, and power requirements will be met.

### API STANDARD 670

The American Petroleum Institute has published Standard 670 as an aid to the procurement of standardized non-contacting vibration, axial position, and temperature monitoring systems. The standard is based on the accumulated knowledge and experience of petroleum refiners and monitoring system manufacturers. API Standard 670 is a valuable reference tool for all machinery users and manufacturers, and is highly recommended as a guide for defining, purchasing, and installing machinery monitoring systems.

API 670 was written to define reliable protection systems for rotating equipment operating in the harsh conditions found in oil production, refining, and chemical processing. SKF RYTON based Eddy Current Probes were designed using a unique temperature chamber to test the Probes over the wide temperature range required by API. The output sensitivity of conventional Eddy Current Probe systems typically falls off as temperature increases. A unique Probe winding technique was developed by SKF that strives to maintain output sensitivity over the specified temperature range.

“Super tough” Eddy Current Probe systems are thoroughly field tested and proven, with thousands of units installed.

SKF has been using RYTON in its transducer designs for many years. RYTON’s strength approaches that of metal. The material is now beginning to be used in the manufacture of automobile engine camshafts. That’s what we mean when we say “Super tough”.

SKF Eddy Current Probes are available in a variety of case mounting configurations and length options to meet difficult installation requirements.

RYTON is impervious to any solvent at temperatures up to +400°F (+205°C). For this reason, SKF Driver Housings are also made of this same super tough material. An added benefit is that there is no longer a need to electrically isolate drivers during installation to prevent troublesome ground loops. RYTON’s proven resistance to extreme harsh environments protects the complex electronics required to operate Eddy Current Probes. An internal sealing system protects these components from moisture ingress and corrosion. This increases system reliability by eliminating the need to totally encapsulate these components. Due to its unique construction, both the Driver Housing and the internal circuits react to severe thermal excursions at the same rate. This reduces internal stresses created by routine machinery transients or load changes, providing for a longer driver life.

SKF Drivers are EMI/RFI shielded, and the mounting scheme allows them to fit the same “footprint” as previous SKF Driver Housings, or they can be snapped onto type C-DIN rails for high density applications and quick installation. The compression connector for terminating the power and signal wiring further aids in the ease and cost of installation. A fixed connector version is also available.

SKF Eddy Current Probe systems are constantly temperature and performance tested in a continuing effort to improve what is already the best Probe available for the measurement of vibration in rotating equipment. They are available with armored and fiberglass sleeving, and may be offered EECS (BASEEFA)/CSA/FM certified.

The small tip diameter (5mm) of the CMSS 65 Eddy Current Probe systems, coupled with the stringent controls under which they are produced, effectively reduces calibration error due to shaft curvature. This makes the CMSS 65 an exceptional choice for measuring vibration in small diameter shafts. The CMSS 65 is available in 5 meter systems (Probe with Integral Cable, or a combination of Probe Cable and Extension Cable) and has a typical usable range of 10 mils to 90 mils with a 200 mV/mil sensitivity. A specific CMSS 665 Driver is required for each of the standard length systems (refer to chart on page 3).

The larger tip diameter (8mm) of the CMSS 68 SKF Transducer is used for large diameter shafts as well as long range axial position (thrust) measurements. The CMSS 68 is available in 5, 10 or 15 meter systems and has a typical usable range of 10 mils to 100 mils with a 200 mV/mil (7.87 V/mm) sensitivity. The CMSS 668-5 Driver provides a usable range of 15 mils to 160 mils with a sensitivity of 100 mV/ mil (3.94 V/mm); it is available only as a 10 meter system.

Temperature conversion table.

Fahrenheit to Celsius: °C = 5/9 (°F - 32)					
Celsius to Fahrenheit: °F = 9/5 (°C) + 32					
Conversion Between °F and °C					
← °F			← °F		
°C	°C >	°F	°C	°C >	°F
-40.0	-40.0	-40.0	+4.4	40.0	104.0
-28.9	-20.0	-4.0	10.0	50.0	122.0
-23.3	-10.0	+14.0	15.6	60.0	140.0
-20.6	-5.0	23.0	21.1	70.0	158.0
-17.8	0	32.0	26.7	80.0	176.0
-15.9	+5.0	41.0	32.2	90.0	194.0
-12.2	10.0	50.0	37.8	100.0	212.0
-6.7	20.0	68.0	93.3	200.0	392.0
-1.1	30.0	86.0			

Length conversion table.

0.5 Meters	≈ 20 Inches (1.7 Feet)
1.0 Meters	≈ 39 Inches (3.3 Feet)
5.0 Meters	≈ 196 Inches (16.0 Feet)
10.0 Meters	≈ 393 Inches (33.0 Feet)
15.0 Meters	≈ 590 Inches (49.0 Feet)
Mils × (25.4 × 10 <sup>-6</sup> ) = Microns	
Microns ÷ (25.4 × 10 <sup>-6</sup> ) = Mils	
1 Mils = 25.4 Microns	80 Mils = 2.0320mm
5 Mils = 127.0 Microns	90 Mils = 2.2860mm
10 Mils = 254.0 Microns	100 Mils = 2.5400mm
20 Mils = 508.0 Microns	110 Mils = 2.7940mm
30 Mils = 762.0 Microns	120 Mils = 3.0480mm
40 Mils = 1.0160mm	130 Mils = 3.3020mm
50 Mils = 1.2700mm	140 Mils = 3.5560mm
60 Mils = 1.5240mm	150 Mils = 3.8100mm
70 Mils = 1.7780mm	

# CMSS 65/CMSS 665 Series 5mm Eddy Probe System RYTON® – Based Eddy Current Transducers



**Option now available with either the standard removable/reversible connector or the optional permanent fixed connector.**



## Specifications

The following specifications apply to a complete CMSS 65 Eddy Current Probe System comprising a CMSS 65 Eddy Current Probe, a CMSS 958 Extension Cable and a CMSS 665 or CMSS 665P Driver. **These specifications may vary with different options and systems configurations.**

### ELECTRICAL

**Usable Range:** 80 mils (10 mils to 90 mils)

**Sensitivity:** 200 mV/mil;  $\pm 5\%$  of 200 mV/mil, (-24 Vdc supply) at +73°F (+23°C)

**Linearity:**  $\pm 1$  mil of best straight line over 80 mil range of unit at +73°F (+23°C)

**Frequency Range:** DC to 600,000 CPM; down maximum of 3 dB at 600,000 CPM

### Driver Signal Output:

**Impedance:** Minimum calibrated load resistance of 3k  $\Omega$ ; output is protected against miswiring

**Voltage:** Nominal 200 mV/mil corresponding to -18 Vdc at 90 mils with -24 Vdc supply

**Interchangeability:** Probes, Extension Cables and Drivers may be interchanged with 5% or less

performance change without recalibration. All units factory calibrated at +73°F (+23°C). Trim calibration adjustment on Driver provides duplication of characteristics after replacement of any component.

**Power Supply Requirements:** 15 mA from -24 Vdc to -30 Vdc

### ENVIRONMENTAL AND MECHANICAL

## CMSS 65 Eddy Current Probe

**Operating Temperature Range:** -30°F to +250°F (-35°C to +120°C)

EECS (BASEEFA) tagged are limited to +212°F (+100°C) maximum.

**Differential Pressure:** To 60 psi

**Case Material:** 300 Stainless Steel

**Tip Material:** RYTON®

**Connectors:** Nickel plated stainless steel; weatherproof, sealable

**Cable:** Coaxial with Teflon® insulation; High tensile and flexible strength

**Mounting:** Any position; recommend clearance of 1/2 Probe Tip diameter around the Probe Tip to maintain factory calibration.

## CMSS 665 and CMSS 665P Driver

**Operating Temperature Range:** -30°F to +150°F (-35°C to +65°C)

**Connections:** (Power, Signal, GND) Five terminal removable and reversible compression terminal block accepting up to 14 AWG wire. Three connections necessary per block (-24 Vdc; GND; Signal). The CMSS 665P has a permanent fixed connector with same connection characteristics.

**Mounting:** C-DIN Rail Mount which bolts onto Driver enclosure, or the standard four number 10 clearance holes in a square on (2.5") 63mm centers.

## CMSS 958 Extension Cable

Temperature ranges, connectors, cable same as CMSS 65 Eddy Current Probe.





## CMSS 65/CMSS 665 Series 5mm Eddy Probe System

### Part 2: Extension Cable (SKF Standard: CMSS 958-00-040)

CMSS 958

CABLE		LENGTH (Compatible System Listed)	
Standard	00	CMSS 665, 2.0m CMSS 65	030
Armored	01	CMSS 665, 1.0m CMSS 65	040
Fiberglass Sleeved	02	CMSS 665, 0.5m CMSS 65	045
CSA/FM/EECS (BASEEFA) (Intrinsically Safe) Certified	09		
CSA/FM/EECS (BASEEFA) (Intrinsically Safe) Certified and Armored	0A		
FM (non-incendive)	0H		
FM (non-incendive) Armored	0J		

### Part 3: Driver (SKF Standard: CMSS 665)

**Drivers containing the "P" in the model number denote those models with permanent fixed connector.**

#### CMSS 665/CMSS 665P

SKF Standard (200 mV/mil). Use with 1.0m Probe and 4.0m Extension Cable, 0.5m Probe and 4.5m Extension Cable or 5.0m Probe.

#### CMSS 665-8/CMSS 665P-8

Specifications same as standard driver, that is also filled with potting material to provide additional measure of protection when operated in adverse environmental conditions (200 mV/mil).

#### CMSS 665-16-9/ CMSS 665P-16-9

CSA/FM/BASEEFA (Intrinsically Safe) Certified Driver for 5.0m System. Use with CSA/FM/BASEEFA (Intrinsically Safe) Certified 1.0m CMSS 65 Probe and 4.0m CMSS 958 Extension Cable. For intrinsic safety installations drivers must be installed with intrinsic safety (I-S) barriers.

**Usable Range:** 45 mils (10 mils to 55 mils)

**Sensitivity:** 200 mV/mil, ± 5% of 200 mV/mil at +73°F (+23°C) (-24 Vdc supply)

**Linearity:** ± 1 mil from best straight line over 45 mil range at +73°F (+23°C)

#### CMSS 665-16-XX/ CMSS 665P-16-XX

CSA/FM/BASEEFA (Intrinsically Safe) Certified Driver for 5.0m System calibrated for shaft materials other than standard 4140 stainless steel. Use with CSA/FM/BASEEFA (Intrinsically Safe) Certified 1.0m CMSS 65 Probe and 4.0m CMSS 958 Extension Cable. For intrinsic safety installations drivers must be installed with intrinsic safety (I-S) barriers.

**Usable Range:** Best attainable for specific shaft material provided. Customer to provide identification of shaft material **and** sample (approximately 2.0" diameter disk, 0.5" thick). Range not expected to exceed the 45 mils of standard unit.

**Sensitivity:** 200 mV/mil, ± a to be determined (TBD) percentage of 200 mV/mil dependent on the shaft sample material (-24 Vdc supply).

**Linearity:** ± the minimum deviation (in mils) from the best straight line attainable for the sample shaft material provided.

#### CMSS 665-20-00/CMSS 665P-20-00

FM (non-incendive) Certified Driver for the 5.0m System. Use with FM (non-incendive) Certified 1.0m CMSS 65 Probe and CMSS 958 Extension Cable. The installed system is FM approved for Class 1, Division 2, Groups A, B, C, and D when connected in accordance with National Electric Code®.

**Usable Range:** 80 mils (10 mils to 90 mils)

**Sensitivity:** 200 mV/mil, ± 5% of 200 mV/mil, (-24 Vdc supply) at +73°F (+23°C)

**Linearity:** ± 1 mil of best straight line over 80 mil range of unit at +73°F (+23°C)

– NOTE –

**All circuit boards used in SKF CMSS 665 Series Drivers are conformal coated as standard procedure.**

# CMSS 68/CMSS 668 Series 8mm Eddy Probe System RYTON® – Based Eddy Current Transducers



**Option now available with either the standard removable/reversible connector or the optional permanent fixed connector.**



## Specifications

The following specifications apply to a complete CMSS 68 Eddy Current Probe System comprising a CMSS 68 Eddy Current Probe, a CMSS 958 Extension Cable and a CMSS 668 Driver. *These specifications may vary with different options and systems configurations.*

### ELECTRICAL

**Usable Range:** 90 mils (10 mils to 100 mils)

**Sensitivity:** 200 mV/mil;  $\pm 5\%$  of 200 mV/mil, (-24 Vdc supply) at +73°F (+23°C)

**Linearity:**  $\pm 1$  mil of best straight line over 90 mil range of unit at +73°F (+23°C)

**Frequency Range:** DC to 600,000 CPM; down maximum of 3 dB at 600,000 CPM

### Driver Signal Output:

**Impedance:** Minimum calibrated load resistance of 3k  $\Omega$ ; output is protected against miswiring

**Voltage:** Nominal 200 mV/mil corresponding to -18 Vdc at 90 mils with -24 Vdc supply

**Interchangeability:** Probes, Extension Cables and drivers may be interchanged with 5% or less

performance change without recalibration. All units factory calibrated at +73°F (+23°C). Trim calibration adjustment on Driver allows duplication of exact characteristics after replacement of any component.

**Power Supply Requirements:** 15 mA from -24 Vdc to -30 Vdc

### ENVIRONMENTAL AND MECHANICAL

#### CMSS 68 Eddy Current Probe

**Operating Temperature Range:** -30°F to +250°F (-35°C to +120°C)

EECS (BASEEFA) tagged are limited to +212°F (+100°C) maximum.

**Differential Pressure:** To 60 psi

**Case Material:** 300 Stainless Steel

**Tip Material:** RYTON®

**Connectors:** Nickel plated stainless steel; weatherproof, sealable

**Cable:** Coaxial with Teflon® insulation; High tensile and flexible strength

**Mounting:** Any position; recommend clearance of 1/2 Probe Tip diameter around the Probe Tip to maintain factory calibration.

#### CMSS 668 and CMSS 668P Driver

**Operating Temperature Range:** -30°F to +150°F (-35°C to +65°C)

**Connections:** (Power, Signal, GND) Five terminal removable and reversible compression terminal block accepting up to 14 AWG wire. Three connections necessary per block (-24 Vdc; GND; Signal). The CMSS 668P has a permanent fixed connector with same connection characteristics.

**Mounting:** C-DIN Rail Mount which bolts onto Driver enclosure, or the standard four number 10 clearance holes in a square on (2.5") 63mm centers.

#### CMSS 958 Extension Cable

Temperature ranges, connectors, cable same as CMSS 68 Eddy Current Probe.

# CMSS 68/CMSS 668 Series 8mm Eddy Probe System

## Ordering Information

DIMENSIONS IN INCHES, EXCEPT AS NOTED

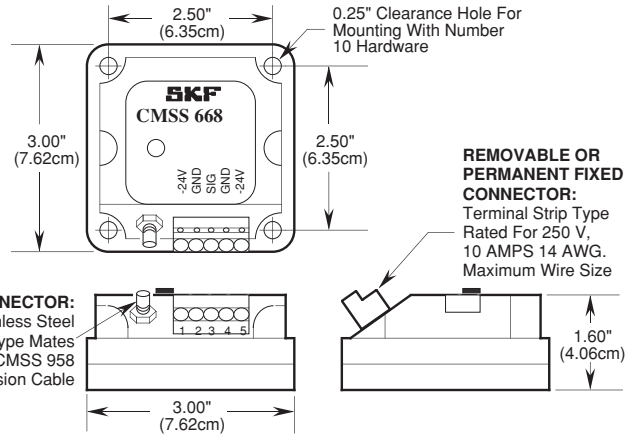
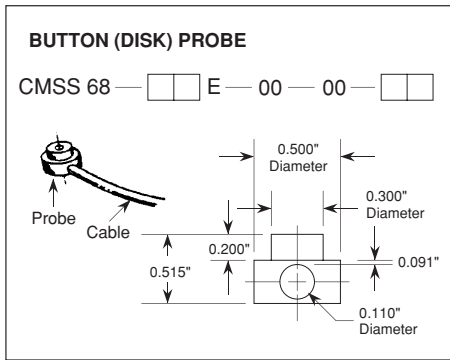
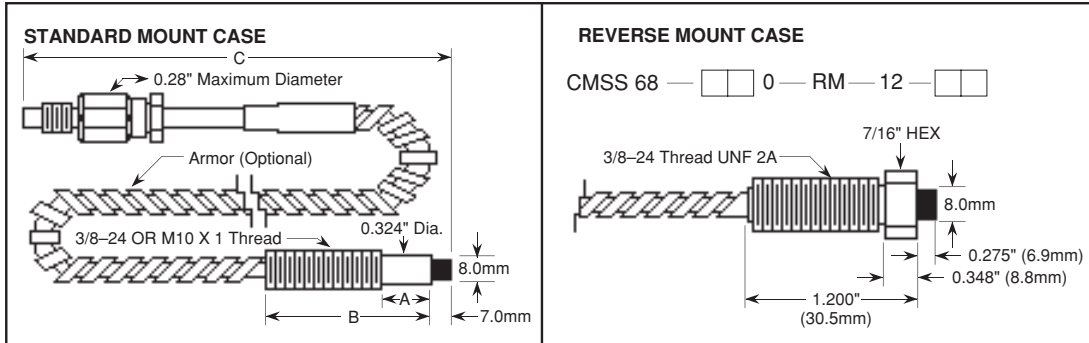

## Part 1: Eddy Current Probe (SKF Standard: CMSS 68-000-00-12-10)

**CMSS 68** — [ ] — [ ] — [ ] — [ ] — [ ]

CABLE	
Standard	00
Armored	01
Fiberglass Sleeved	02
CSA/FM/EECS (BASEEFA) (Intrinsically Safe) Certified	07
CSA/FM/EECS (BASEEFA) (Intrinsically Safe) Certified and Armored	08
FM (non-incendive)	09
FM (non-incendive) Armored	0B

CASE	
0	3/8-24 Threads (Standard)
1	M10 X 1 Threads
4	No Case
E	Button Probe (Fiberglass)

"A" UNTHREADED CASE LENGTH	
Fully Threaded	00
0.1 Inches To	01
5.0 Inches To	To
Unthreaded	50
5.1 Inches To	51
9.9 Inches	To
Reverse Mount	99
3/8-24 Thread	RM

"B" CASE LENGTH	
Standards:	
No Case	00
0.8 Inches	08
1.2 Inches	12
1.5 Inches	15
2.0 Inches	20
2.5 Inches	25
3.0 Inches	30
4.0 Inches	40
4.7 Inches	47
6.0 Inches	60
9.0 Inches	90
SPECIALS	
0.9 To 5.9 Inches	09
To	To
59	59
9.1 To 9.9 Inches	91
To	To
99	99

"C" OVERALL LENGTH +1	
05	0.5 Meter
10	1.0 Meter (Standard)
5A	5.0 Meter
AA	10.0 Meter
FA	15.0 Meter

+1: Length is **Nominal Electrical**: physical length may vary.

**Compatible Systems:**

0.5m Probe:  
5.0m System:  
CMSS 958 - XX - 045/CMSS 668

1.0m Probe:  
5.0m System:  
CMSS 958 - XX - 040/CMSS 668

5.0m Probe:  
5.0m System: CMSS 668

10.0m Probe:  
10.0m System: CMSS 668-1

15.0m Probe:  
15.0m System: CMSS 668-2

The 5A, AA, FA, units have integral cable and mate directly to the Driver.

**- NOTE -**

See catalog page 34 for recommended Intrinsic Safety (I-S) Barriers and entity parameters.

# CMSS 68/CMSS 668 Series 8mm Eddy Probe System

## Part 2: Extension Cable (SKF Standard: CMSS 958-00-040)

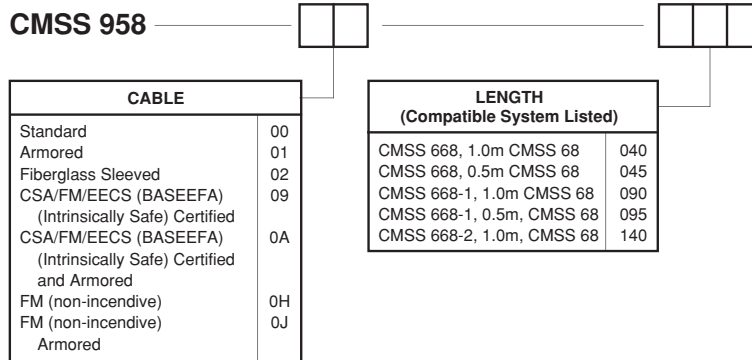

## Part 3: Driver (SKF Standard: CMSS 668)

**Drivers containing the "P" in the model number denote those models with permanent fixed connector.**

### CMSS 668/CMSS 668P

SKF Standard (200 mV/mil). Use with 1.0m Probe and 4.0m Extension Cable, 0.5m Probe and 4.5m Extension Cable or 5.0m Probe.

### CMSS 668-1/CMSS 668P-1

Driver for 10.0m System (200 mV/mil). Use with 1.0m Probe and 9.0m Extension Cable or 10.0m Probe.

**Usable Range:** 90 mils (10 mils to 100 mils)

**Sensitivity:** 200 mV/mil, ± 10% of 200 mV/mil (-24 Vdc supply) at +73°F (+23°C)

**Linearity:** ± 1.5 mil from best straight line at +73°F (+23°C)

### CMSS 668-2/CMSS 668P-2

Driver for 15.0m System (200 mV/mil). Use with 1.0m Probe and 14.0m Extension Cable or 15.0m Probe.

**Usable Range:** 90 mils (10 mils to 100 mils)

**Sensitivity:** 200 mV/mil, ± 10% of 200 mV/mil (-24 Vdc supply) at +73°F (+23°C)

**Linearity:** ± 1.5 mil from best straight line over 90 mil range at +73°F (+23°C)

### CMSS 668-5/CMSS 668P-5

Driver for extended range (15 mils to 160 mils) used with 10.0m System. Use with 1.0m Probe and 9.0m Extension Cable or 10.0m Probe.

**Usable Range:** 145 mils (15 mils to 160 mils)

**Sensitivity:** 100 mV/mil, ± 10% of 200 mV/mil (-24 Vdc supply) at +73°F (+23°C)

**Linearity:** ± 1 mil from best straight line over 145 mil range at +73°F (+23°C)

### CMSS 668-8/CMSS 668P-8

Specifications same as standard Driver, that is also filled with potting material to provide additional measure of protection where operated in adverse environmental conditions (200 mV/mil).

### CMSS 668-16-9/ CMSS 668P-16-9

CSA/FM/BASEEFA (Intrinsically Safe) Certified Driver for 5.0m System. Use with CSA/FM/BASEEFA (Intrinsically Safe) Certified 1.0m CMSS 68 Probe and 4.0m CMSS 958 Extension Cable. For intrinsic safety installations drivers must be installed with intrinsic safety (I-S) barriers.

**Usable Range:** 65 mils (10 mils to 75 mils)

**Sensitivity:** 200 mV/mil, ± 5% of 200 mV/mil (-18 Vdc or -24 Vdc supply) at +73°F (+23°C)

**Linearity:** ± 1 mil from best straight line over 65 mil range at +73°F (+23°C)

- NOTE -

*All circuit boards used in SKF CMSS 668 Series Drivers are conformal coated as standard procedure.*



## CMSS 68/CMSS 668 Series 8mm Eddy Probe System

### Part 3: Driver (SKF Standard: CMSS 668)

**Drivers containing the "P" in the model number denote those models with permanent fixed connector.**

#### CMSS 668-16-15/CMSS 668P-16-15

CSA/FM/BASEEFA (Intrinsically Safe) Certified Driver for 10.0m System. Use with CSA/FM/BASEEFA (Intrinsically Safe) Certified 1.0m CMSS 68 probe and 9.0m CMSS 958 Extension Cable. For intrinsic safety installations drivers must be installed with intrinsic safety (I-S) barriers.

**Usable Range:** 60 mils (10 mils to 70 mils)

**Sensitivity:** 200 mV/mil,  $\pm 10\%$  of 200 mV/mil (-18 Vdc or -24 Vdc supply) at +73°F (+23°C)

**Linearity:**  $\pm 1.5$  mil from best straight line over 60 mil range at +73°F (+23°C)

#### CMSS 668-16-XX/CMSS 668P-16-XX

CSA/FM/BASEEFA (Intrinsically Safe) Certified Driver for 5.0m System calibrated for shaft materials other than standard 4140 stainless steel. Use with CSA/FM/BASEEFA (Intrinsically Safe) Certified 1.0m CMSS 68 probe and 4.0m CMSS 958 Extension Cable. For intrinsic safety installations drivers must be installed with intrinsic safety (I-S) barriers.

**Usable Range:** Best attainable for specific shaft material provided. Customer to provide identification of shaft material **and** sample (approximately 2.0" diameter disk, 0.5" thick). Range not expected to exceed the 60 mils of the standard unit.

**Sensitivity:** 200 mV/mil,  $\pm a$  to be determined (TBD) percentage of 200 mV/mil dependent on the shaft sample material (-18 Vdc or -24 Vdc supply).

**Linearity:**  $\pm$  the minimum deviation (in mils) from the best straight line attainable for the sample shaft material provided.

#### CMSS 668-20-00/CMSS 668P-20-00

FM (non-incendive) Certified Driver for the 5.0m System. Use with FM (non-incendive) Certified 1.0m CMSS 65 Probe and CMSS 958 Extension Cable. The installed system is FM approved for Class 1, Division 2, Groups A, B, C, and D when connected in accordance with National Electric Code®.

**Usable Range:** 80 mils (10 mils to 100 mils)

**Sensitivity:** 200 mV/mil,  $\pm 5\%$  of 200 mV/mil, (-24 Vdc supply) at +73°F (+23°C)

**Linearity:**  $\pm 1$  mil of best straight line over 80 mil range of unit at +73°F (+23°C)

– NOTE –

**All circuit boards used in SKF CMSS 668 Series Drivers are conformal coated as standard procedure.**

## CMSS 62/CMSS 620 Series 19mm Eddy Probe System



### For long range (wide gap) measurements

- 60 mils to 300 mils usable range at 50 mV/mil (1.96 V/mm) sensitivity
- 10.8 meter overall cable lengths
- Dependable eddy current operation
- Readily interchangeable on-site
- Durable, high-temperature probe tip
- Rugged long life connectors



The CMSS 62 Eddy Probe, when used with a CMSS 620-2 Driver, has a usable range that is typically 60 mils to 300 mils. The standard output sensitivity of the system is 50 mV/mil (1.96 V/mm).

The CMSS 62 packs a long range into a rugged industrial probe. It is used extensively in those applications involving large position measurement.

Differential expansion measurement is an ideal application for the CMSS 62.

The CMSS 62 is available in several probe case configurations and environmental options to meet a wide range of installation requirements.

### Specifications

The following specifications apply to a system including the CMSS 62 Eddy Probe, CMSS 620-2 Driver and CMSS 900 Extension Cable.

#### ELECTRICAL

**Usable Range:** 60 mils to 300 mils

**Sensitivity:** 50 mV/mil,  $\pm 10\%$   
(1.96 V/mm) (-24 Vdc supply)  
at +73°F (+23°C)

**Linearity:**  $\pm 2$  mil of best straight line from 80 mils to 280 mils gap,  $\pm 10\%$  of 50 mV/mil sensitivity from 80 mils to 280 mils absolute gap at +73°F (+23°C)

**Frequency Range:** Static to 600,000 CPM; down to 3 dB at 600,000 CPM

**Driver Signal Output:**

**Impedance:** 30  $\Omega$

**Current:** 4 mA maximum

**Voltage:**

*Nominal:* 50 mV/mil

*Maximum Output:* -19 V  
with -24 V supply

**Power:** -24 Vdc

### CMSS 620-2 Driver

**Operating Temperature Range:**

-30°F to +150°F (-35°C to +65°C)

**Calibration Probe Temperature:**

+73°F (+23°C)

**Connections (Power, Output,**

**Common):** Three terminal barrier strip  
(accepts #6 spade lugs)

**Mounting Holes:** Four #10 clearance holes

in a square on 2.5" (63mm) centers

**Interchangeability:** Probes and Drivers

may be interchanged with 10% or less performance change without calibration. All units factory calibrated. Trim calibration adjustment on Driver allows duplication of replacement.

#### ENVIRONMENTAL AND MECHANICAL

### CMSS 62 PROBE

**Operating Temperature Range:**

-30°F to +250°F (-35°C to +120°C)

**Case Material:** 300 Stainless Steel

**Connections:** Stainless Steel. Weather-proof, sealable.

**Cable:** Coaxial with Teflon® insulation. High tensile and flexural strength.

**Mounting:** Any position

### CMSS 900 Extension Cable

**Operating Temperature Range:**

-30°F to +250°F (-35°C to +120°C)

**Connections:** Stainless Steel. Weather-proof, sealable.

**Cable:** Coaxial with Teflon® insulation. High tensile and flexural strength.

Typical CMSS 62/CMSS 620-2 Performance

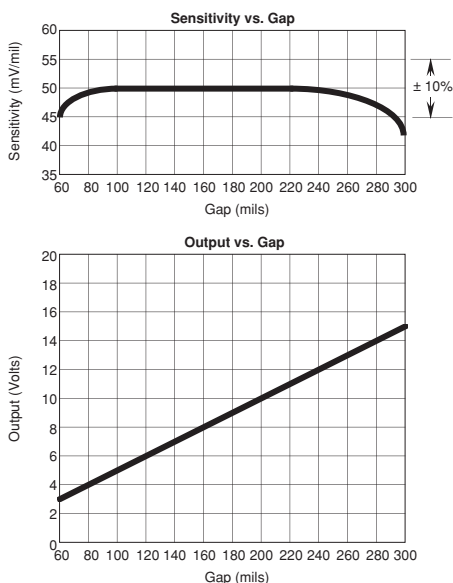

– NOTE –

Performance specifications are based on a 4140 steel target. Consult sales representative for calibration requirements on other materials.

# CMSS 62/CMSS 620 Series 19mm Eddy Probe System

## Ordering Information

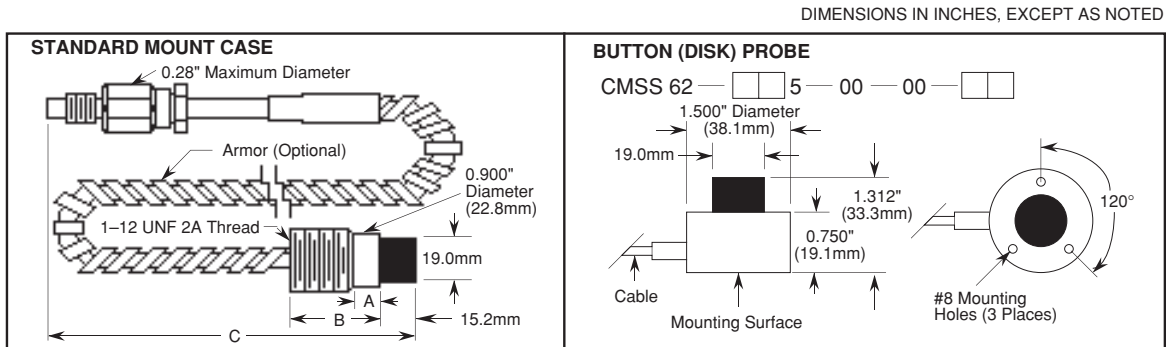

### Part 1: Eddy Current Probe (SKF Standard: CMSS 62-000-00-30-20)

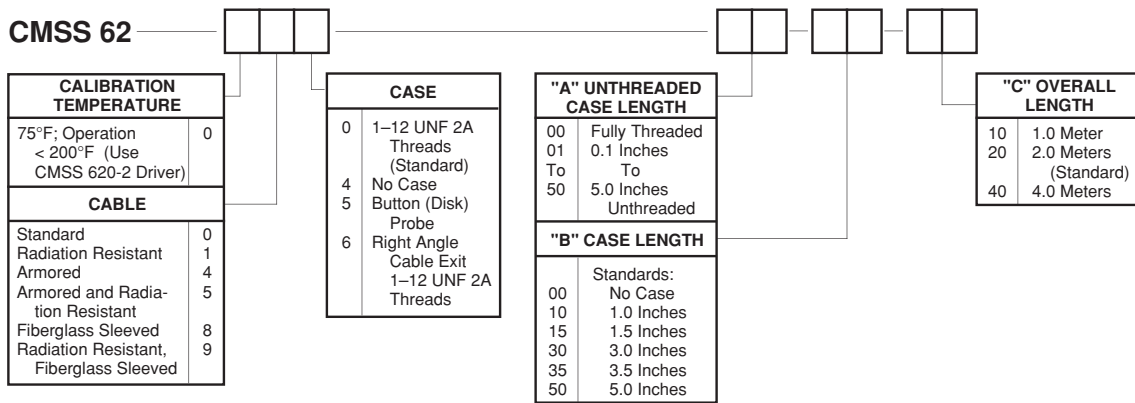

### Part 2: Extension Cable (SKF Standard: CMSS 900-00-088)

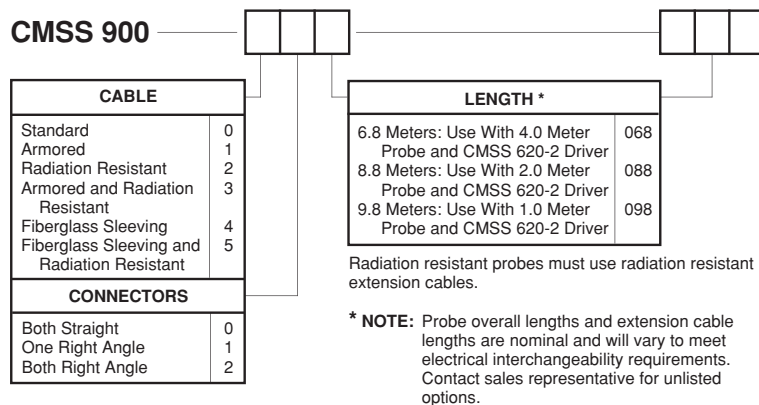

### Part 3: Probe Driver (SKF Standard: CMSS 620-2)

**Use with:** 1.0 Meter Probe and 9.8 Meter Extension Cable  
 2.0 Meter Probe and 8.8 Meter Extension Cable  
 4.0 Meter Probe and 6.8 Meter Extension Cable

# CMSS 920 High Pressure Feedthrough

The SKF Condition Monitoring Model CMSS 920 is a low cost, general purpose High Pressure Feedthrough. The CMSS 920 is principally used to provide a cable exit for internally mounted Eddy Probes in high pressure areas. The unit is available in configurations for one, two, or three cables and the cable lengths on the high pressure and low pressure side may be specified as required to meet particular Eddy Probe System configurations. The internal modular construction allows configuration to customer's specifications.

The CMSS 920's bidirectional pressure rating of 2,000 psi enables the unit to withstand both pressure and vacuum, a critical requirement for refrigeration units which are dehumidified under vacuum and pressurized in normal operation. The

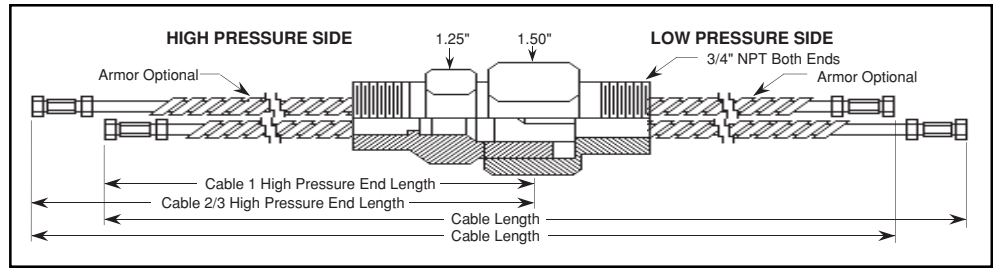

3/4 inch NPT mounting threads on either end enables the CMSS 920 to be installed in a smaller hole. An optional 1-inch NPT thread adapter is available and may replace other high pressure feedthroughs with the CMSS 920.

## Specifications

### PHYSICAL

- Case Material:** Type 303 stainless steel
- Mounting:** Any position, 3/4" NPT threads
- Cable Length of High Pressure End:** Increments of 0.1 meter (Recommend minimum of 0.2 meters)

- Cable Quantity:** 1, 2, or 3 cables
- Cable Armor:** Available
- Customer ID:** 1.5" clear heat-shrink
- Torque:** 60–80 foot-pounds

### DYNAMIC

- Pressure/Vacuum:** 0 to 2,000 psi bidirectional
- Electrical Cable Length:** As required to meet Eddy Probe System configuration

### ENVIRONMENTAL

- Operating Temperature Range:** -30°F to +250°F (-35°C to +120°C)

## Ordering Information: (SKF Standard: CMSS 920-1000-100500-010)

<b>CABLE QUANTITY</b>		<b>CABLE LENGTH +1</b>		<b>HIGH PRESSURE END CONNECTOR</b>	
1 Cable	1	1.0 Meters (For CMSS 65 and CMSS 68)	10	LOW PRESSURE END CONNECTOR	
2 Cables	2	4.0 Meters (For CMSS 65 and CMSS 68)	40	OTHER OPTIONS	
3 Cables	3	4.5 Meters (For CMSS 65 and CMSS 68)	45	Female (Probe or Driver mate)	0
<b>ENVIRONMENT</b>		<b>CABLE 1 HIGH PRESSURE END LENGTH</b>		Male (CMSS958 Extension Cable Mate)	1
Standard	0	<b>CABLES 2 AND 3 HIGH PRESSURE END LENGTH</b>		No Connector	3
<b>ARMOR</b>		Increments Of 0.1 Meter			
No Armor	0	Minimum: 0.2 Meters			
High Pressure End Armor	1	Example: 25 = 2.5 Meters			
Low Pressure End Armor	2	Cable Not Used			
Both Ends Armor	3				
<b>CASE</b>					
Stainless Steel	0				
3/4" To 1" Thread Adapter	1				

+1: Use configuration illustrations and chart below to determine length/compatible system.

When ordering, customers are requested to provide information to define the Eddy Probe System this item will be used with to facilitate calibration.

## Compatible CMSS 920 Systems

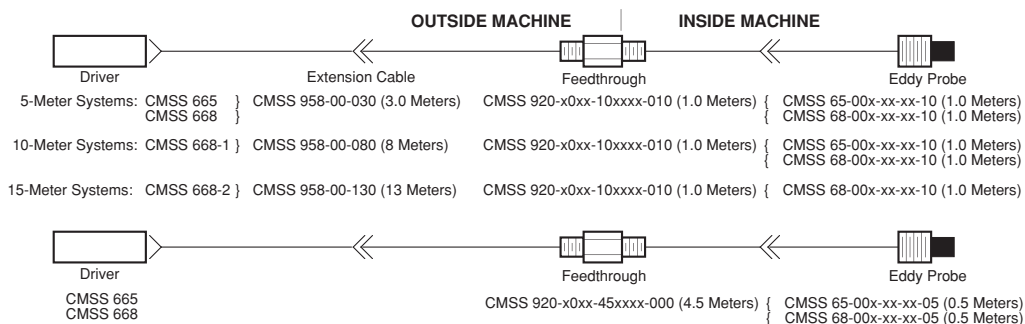

## CMSS 911 Probe Holder/Dual Sensor Holder with Housing

### CMSS 911 Probe Holder

The CMSS 911 Probe Holder with Housing offers an adjustable probe mount with a variety of penetration depths. The integral housing protects the probe cable exit and permits easy access for probe adjustment without machine disassembly. It is recommended that reverse mount probes be used or that standard case probes be ordered with a case length of 1.2 inches and an overall cable length of 0.5 or 1.0 meters. The housing has four 3/4" NPT hubs for conduit attachment (3 close-up plugs provided).

1. Outlet Body (*Part Number 10699400*) *GRR-2*
2. Outlet Body Extension (*Part Number 10699300*) *GRCEX-0*

3. Outlet Body Hub, 3/4" NPT (4 Each)
4. Probe Adapter Union; 3/4" NPT (*Part Number 30180900*)
5. Probe Adapter Collar (*Part Number 30187900*)
6. Hex Head Steel Cap Screw (*Part Number 10702200*)
7. Probe Holder ("Stinger") (*Part Number - Various Depending On Probe Holder Length*)
8. Jam Nut, Integral To Reverse Mount Eddy Probe Case
9. "O" Ring Union Seal (*Part Number 10711803*)
10. "O" Ring Tip Seal (*Part Number 10711800*)

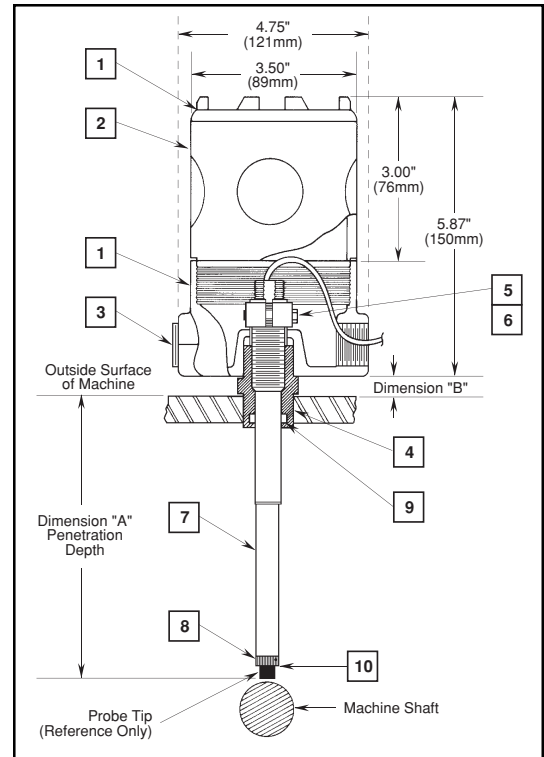

### CMSS 911 Dual Sensor Holder

The CMSS 911 Dual Sensor Holder with or without the housing provides for the mounting, adjustment and protection of the eddy probe as well as provides for mounting an *accelerometer or velocity sensor on the same axis as the eddy probe for absolute vibration measurements*. It is recommended that reverse mount probes be used or that standard case probes be ordered with a case length of 1.2 inches and an overall cable length of 0.5 or 1.0 meters. The housing has four 3/4" NPT hubs for conduit attachment (3 close-up plugs provided).

1. Outlet Dome (*Part Number 10699402*) *4GOU*
2. Seismic Sensor Mounting Adapter (*Part Number 301194200*)

3. Outlet Body (*Part Number 10699401*) *GECXAT-2*
4. End Plug (*Part Number 10746003*) *CUP-2*
5. Probe Adapter Union (*Part Number 30180900*)
6. "O" Ring Union Seal (*Part Number 10711803*)
7. Jam Nut, Integral To Reverse Mount Eddy Probe Case
8. Seismic Sensor Accelerometer/Velocity
9. Probe Adapter Collar (*Part Number 30187900*)
10. Hex Head Steel Cap Screw (*Part Number 10702200*)
11. Probe Holder ("Stinger") (*Part Number - Various Depending On Length*)
12. "O" Ring Tip Seal (*Part Number 10711800*)

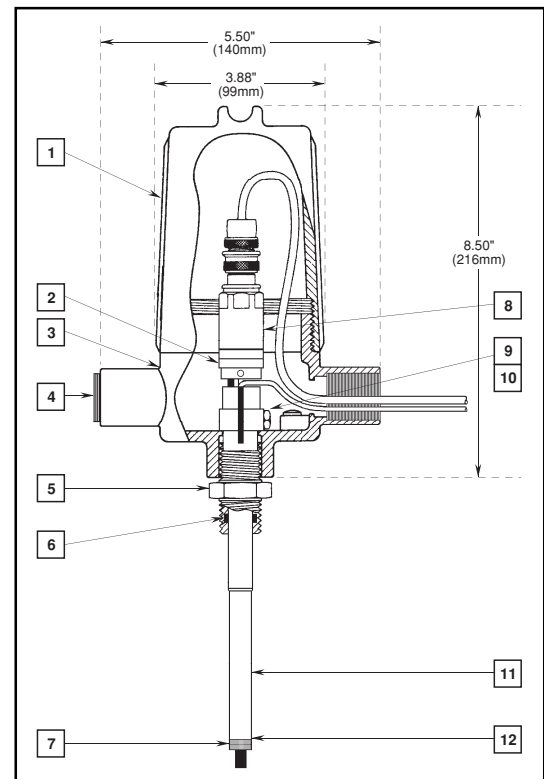



# CMSS 911 Probe Holder/Dual Sensor Holder with Housing

### Intermediate Support/Oil Seal

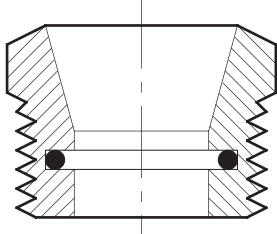

Intermediate support/oil seal. Recommended for use with probe holders 8 inches (203 mm) or longer in length. Provides support and aids in eliminating/minimizing probe holder resonances causing inaccurate probe measurements. For use with probe holders with model numbers CMSS 911-0XX-XXX only.

**Part Number 31194401** (1" – 12 threads).

**Part Number 31194400** (3/4" NPT threads).

### Probe Adapter

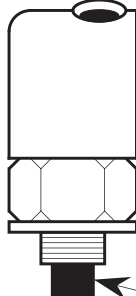

Part Number 30221900  
Probe Adapter 3/8–24 to 1/4–28 used when installing CMSS 61 and CMSS 65 Probes in Probe Holder with 3/8–24 threads.

CMSS 61 and CMSS 65 Probe Tip Assembly (Reference only)

## Ordering Information

### CMSS 911

PROBE THREAD †4	
3/8–24 CMSS 65/CMSS 68 Reverse Mount Standard †5	0
1/4–28 CMSS 65 Standard †6, †8	1
M10 X 1 CMSS 65 and CMSS 68 Reverse Mount With M10 X 1 Case †7	2
DIMENSION B ADAPTER LENGTH	
0.5 Inch (Standard)	0
1.5 Inches †1A	3
2.5 Inches †1B	1
3.5 Inches †1C	2
7.0 Inches †1D	4
OTHER OPTIONS	
None Required	0
Probe Holder WITHOUT Housing	1
Dual Sensor WITH Housing	6
Dual Sensor WITHOUT Housing	7

DIMENSION A PENETRATION DEPTH †2	
Standard Lengths: †3	
Short (1.0" To 2.0")	020
Long (2.0" To 5.0")	
Non-Standard Lengths: †2	
6 Inches	060
7 Inches	070
8 Inches	080
9 Inches	090
10 Inches	100
11 Inches	110
12 Inches	120
13 Inches	130
14 Inches	140
15 Inches	150
16 Inches	160
17 Inches	170

– NOTE –

*Customers are strongly encouraged to use the CMSS 65/CMSS 68 Reverse Mount Eddy Probe Options when mounting Probes in CMSS 911 Holders.*

– NOTE –

*With the ±0.07" adjustment these length stingers should meet all length requirements without trimming or cutting to interim custom lengths (i.e. 9.3", 10.7", etc.).*

- †1A Dimension A penetration depth will be 1.0 inches less than indicated.
- †1B Dimension A penetration depth will be 2.0 inches less than indicated.
- †1C Dimension A penetration depth will be 3.0 inches less than indicated.
- †1D Dimension A penetration depth will be 6.5 inches less than indicated.
- †2 Indicated depth is center of ±0.7" adjustment range for standard CMSS 911 units. Indicated depth is ±0.5" adjustment range for dual sensor units. API 670 recommends maximum of 8 inches of free cantilevered length. Use intermediate support/oil seal for longer lengths.
- †3 Center of adjustment depth may be field cut within the indicated range.
- †4 Probe Adapter 1/4–28 to 3/8–24 threads, Part Number 30221900 is required and must be ordered separately when using CMSS 65/CMSS 61 standard Eddy Current Probes with the larger diameter stringers.
- †5 This option does not require removal of connector of probe cable during field assembly. CMSS 65/CMSS 68 3/8–24 Reverse Mount Eddy Probe is recommended configuration offered in either 5mm or 8mm versions.
- †6 This option size stinger only available in the standard 020 and 050 lengths.
- †7 This option provides "Stingers" with M10 X 1 probe threads and can be used with CMSS 65 and CMSS 68 Reverse Mount Probes with M10 X 1 thread cases.
- †8 Eddy Probe connector must be removed and reinstalled when using this size threaded stinger.

## CMSS 904 Probe Holder

The CMSS 904 Probe Holder provides a rigid mount with provision for external gap adjustment. Conduit may be readily mounted at the cable exit. The CMSS 904 provides 0.75" of adjustment range after installation; a set screw securely locks the adjustment. It is recommended that probes be ordered with a case length of 1.2 inches or use the standard reverse mount probe.

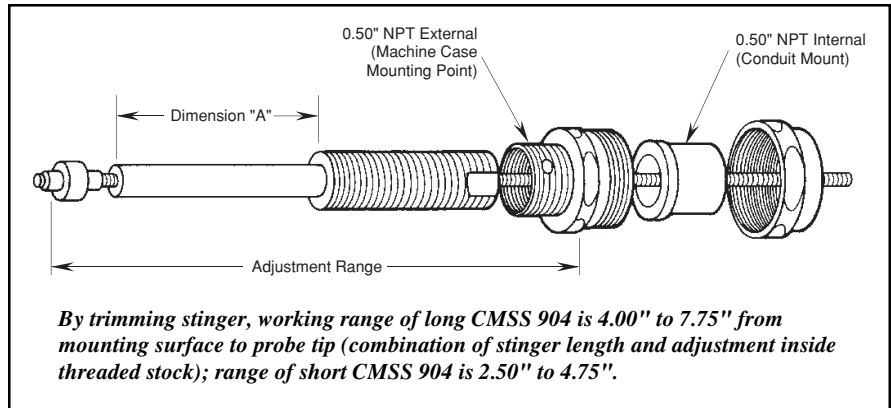

### Ordering Information

#### CMSS 904

PROBE THREAD	
3/8–24 CMSS 65/CMSS 68 Reverse Mount Standard †1	0
OTHER OPTIONS	
None Required	0

DIMENSION "A" "STINGER" DEPTH	
Short (0.75" To 2.50") *	025
Long (1.45" To 5.50") *	055

†1 CMSS 65/CMSS 68 3/8–24 Reverse Mount Eddy Probe is recommended configuration offered in either 5mm or 8mm versions.

\* "Stingers" may be cut down in the field within the indicated ranges.

## CMSS 912 Dual Axial Probe Adapter

The CMSS 912 Dual Axial Probe Adapter provides mounting and protection for two parallel probes for measuring axial thrust position. The probes are mounted on adapters which are installed directly on the machine case through 1/2-inch NPT-threaded holes. The adapters provide for easy gapping of the probes. The enclosure bolts directly to the machine case and protects the probe installation. A removable cover provides access to the installed probe.

It is recommended that probes be ordered with a case length of 1.2 inches and an overall length of 0.5 or 1.0 meters.

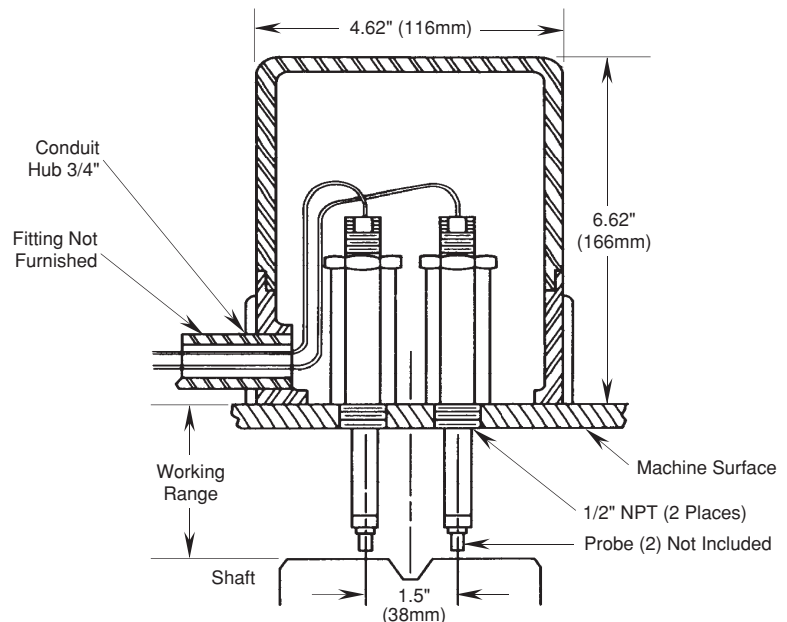

MODEL NUMBER	WORKING RANGE*	PROBE THREAD
CMSS 912-1	1.10" To 2.35"	1/4–28 CMSS 65 Standard
CMSS 912-2	1.30" To 5.35"	1/4–28 CMSS 65 Standard
CMSS 912-3	0.75" To 2.00"	3/8–24 CMSS 68 Standard
CMSS 912-4	0.95" To 5.00"	3/8–24 CMSS 68 Standard

\* Working range with field trim of probe holder.

## Mounting Devices, Adapters, and Packing Glands

The basic design and construction of the SKF Condition Monitoring Eddy Probes insures long, dependable service life. However, proper installation is essential; once adjusted to its optimum position, a probe must be absolutely immovable.

Standardized installation devices are offered for this specific purpose. They eliminate the chore of making special brackets or fixtures for each installation. They also help insure that every SKF Eddy Probe will continue to deliver all the accuracy built into it ... year after year.



(From left to right) CMSS 903 Series Probe Adapters: CMSS 903-1 Probe Holder; CMSS 903-2 Probe Holder; CMSS 903-3 Probe Holder.

## CMSS 903 Series Mounting Brackets

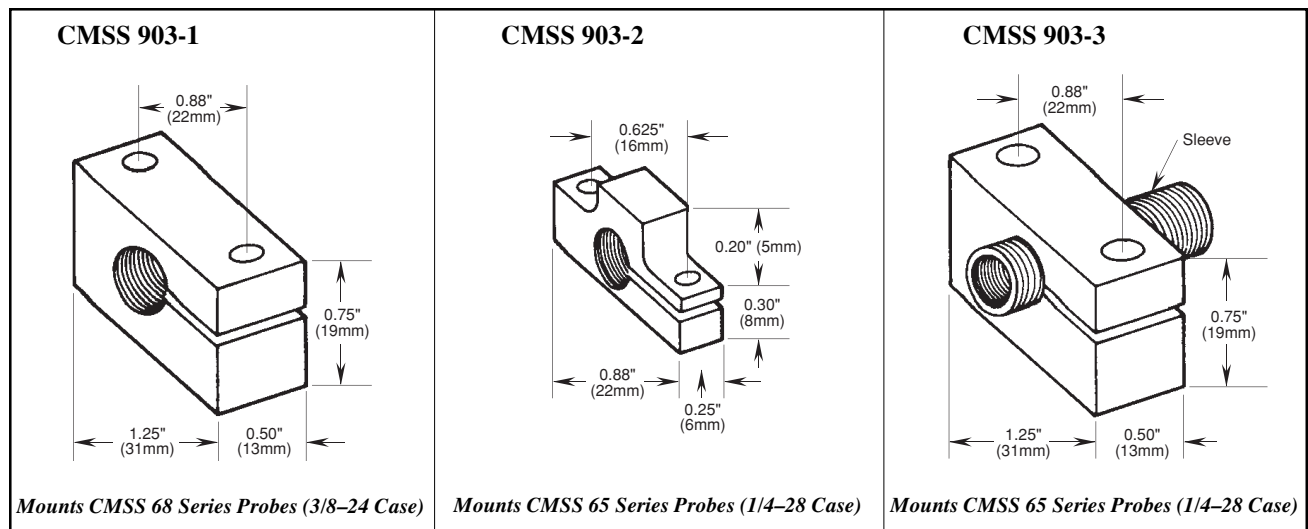

**CMSS 903 Mounting Brackets** are used in those installations requiring probe mounting in the machine's internal area.

**CMSS 903-1 Probe Holders** are used to install CMSS 68 Series Eddy Probes on flat machine surfaces. Threaded (3/8–24) and slotted, they insure a firm grip on the probe, once it is adjusted to final operating position. Two mounting holes accommodate #10 high tensile Allen head cap screws (not provided) which are normally secured with safety wires.

**Material:** Anodized aluminum.

**CMSS 903-2 Probe Holders** are used for installing CMSS 65 Series Eddy Probes on flat machine surfaces when space is at a premium. They are threaded (1/4–28) and slotted to insure a firm grip after final adjustment. Mounting holes accommodate two #6 high tensile Allen head cap screws with safety wire holes (not provided).

**Material:** Stainless Steel.

**CMSS 903-3 Probe Holders** are similar to the CMSS 903-1 but are designed to hold CMSS 65 Series Eddy Probes and, in addition, permit final adjustment where it is not

possible to turn the Probe itself. This is especially convenient for installation of Probes with armored or otherwise protected leads.

The Probe is threaded into a sleeve, which mates with a left-hand thread in the main body of the Holder. Turning the sleeve then sets the Probe position; it is not necessary to turn the Probe itself. Both Holder and sleeve are slotted to insure a firm grip on the Probe. Mounting holes accommodate two #10 high tensile Allen head cap screws with safety wire holes (not provided).

**Material:** Anodized aluminum.

## CMSS 30112000 Series Cable Packing Gland Assembly

The CMSS 30112000 Series Cable Packing Gland Assembly offers a splash-proof cable exit from the machine case. They are available in 1 or 2 cable exit versions and with either a

1/2" or 3/4" NPT male thread for screwing into the machine housing. It is an effective and easily installed low pressure (60 psi/4 bars) seal. The internal oil resistant neoprene packing as well as washers are split to allow cable installation without connector removal.

The Cable Packing Glands are typically used for exiting the Eddy Probe Cable or Extension Cable for internally installed Eddy Probes.

The Cable Packing Gland will not provide a seal for armored cables.

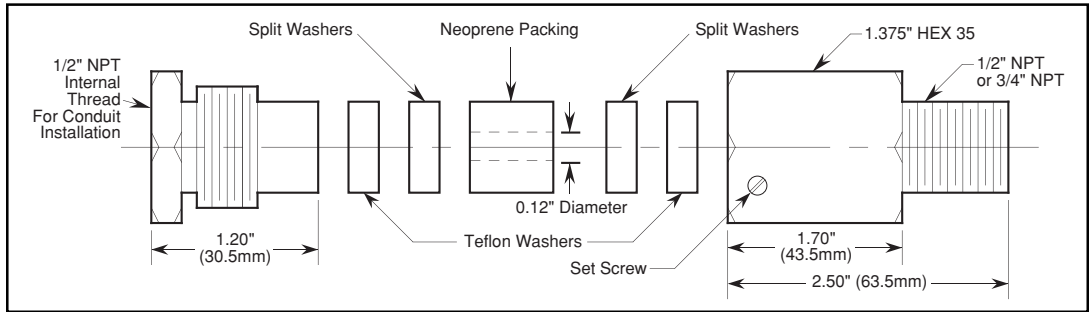

### Ordering Information

**CMSS 30112000**

One (1) cable exit, 1/2" NPT thread

**CMSS 30112001**

Two (2) cable exit, 1/2" NPT thread

**CMSS 30112003**

One (1) cable exit, 3/4" NPT thread

**CMSS 30112004**

Two (2) cable exit, 3/4" NPT thread

**CMSS 30112006 †1**

Two (2) cable exit, 1/2" NPT thread

**CMSS 30112007 †1**

Two (2) cable exit, 3/4" NPT thread

†1 The CMSS 30112006 and CMSS 30112007 models have split washers which can accommodate an Eddy Probe Cable and an Accelerometer/Velocity Transducer Cable for internal installations of absolute Vibration Transducers.

## CMSS 30837800 1/2" or 3/4" NPT Probe Adapter

The Probe Adapter is used to mount a probe with a 1/4–28 or 3/8–24 thread in a machine case which will accept the 1/2" or 3/4" NPT fitting. Conduit or a junction box may be mounted on the exterior side of the adapter.

### Ordering Information

**CMSS 30837800**

3/8–24 internal thread for CMSS 68 style probes. 1/2" NPT external thread.

**CMSS 30837801**

1/4–28 internal thread for CMSS 65 style probes. 1/2" NPT external thread.

**CMSS 30837802**

3/8–24 internal thread for CMSS 68 style probes. 3/4" NPT external thread.

**CMSS 30837803**

1/4–28 internal thread for CMSS 65 style probes. 3/4" NPT external thread.

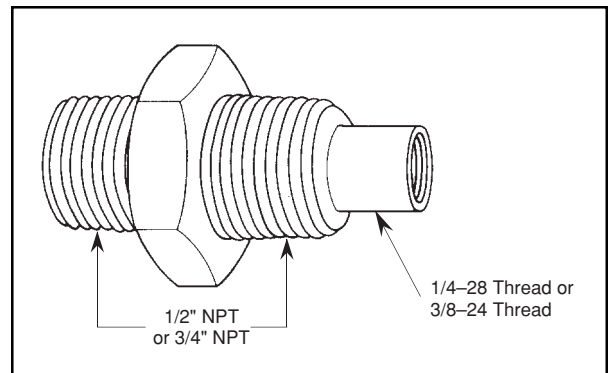

# Explosion-Proof Housings For DIN-Rail Mount Drivers

## Explosion-Proof Housings

Explosion-Proof and Dust-Tight Housings

Class I, Group C and D

Class II, Groups E, F, and G

Class III,

UL Standard 886

CSA Standard C22.2,  
Number 30 1970

The Explosion-Proof housing is designed for use in environments classified as hazardous. The housing is manufactured of aluminum alloy with a copper content less than 0.3% maximum. On three sides the bosses are drilled and tapped for 3/4" NPT conduit fittings. The dome type housing is specified requiring a minimum of floor space for fixture mounting.



## Ordering Information

Explosion-Proof Housings for RYTON™ DIN-Rail Mount Drivers. The units come with all hardware ready for assembly and installing the drivers.

**CMSS 31091700** Explosion-Proof Housing for maximum four drivers

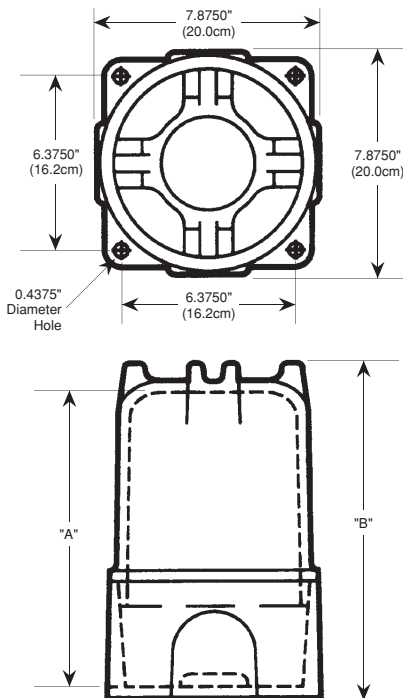

Catalog Number	"A" Inside Dome	"B" Overall Height	Diameter Cover Opening	Mounting Hole Size	Weight Each Pounds
CMSS 31091700	10.2500" (26.0cm)	11.4375" (29.0cm)	6.8750" (17.5cm)	0.4375"	15 (6.5 kg)

- NOTE -

Please refer to reference information in the back of this catalog for definitions, standards and cross references.



## Weatherproof Housings

### Weatherproof Housing (NEMA 4 and 4X)

Meets requirements for NEMA Type 4, Type 4X, Type 12 and Type 13.

UL 508 Type 4 and Type 4X

CSA Type 4.

IEC 529, IP66 (European Standard)

### Weatherproof Housings For Protection From Adverse Environmental Conditions

SKF Condition Monitoring product line offers three types of housings to provide protection from adverse environmental conditions for DIN-Rail Mountable Eddy Probe Drivers.

### Water-Resistant Housing

Enclosures are intended for indoor or outdoor use primarily to provide a degree of protection against corrosion, windblown dust and rain, splashing water, and hose-directed water; undamaged by the formation of ice on the enclosure. The housings are constructed of 14 or 16 gauge steel with seams continuously welded.

**Holes and cable clamp fittings are provided.** The cover is held in place by steel clamps on four sides of cover to assure water tight integrity. There is an oil-resistant gasket held in place with oil resistant adhesive. Finish is ANSI 61 gray polyester powder coating. Meets NEMA 4 criteria.

### Water and Corrosion Resistant Housing (Stainless Steel)

Meets the same criteria as the Water Resistant Housing in addition to being manufactured of stainless steel to meet the CORROSION RESISTANT criteria. Finish is unpainted polished surface. Meets NEMA 4X criteria.

### Ordering Information

Weatherproof housings for RYTON™ DIN-Rail mount Drivers.

#### Area Classification — (Clamp Cover)

NEMA/EEMAC Type 4, Type 12 and Type 13

UL50 Type 4, Type 12, Type 13

UL508 Type 4, Type 12, Type 13

CSA Type 4

IEC 529, IP66

#### CMSS 31092100 †1

Weatherproof Housing for maximum three Drivers

#### CMSS 31092200 †1

Weatherproof Housing for maximum six Drivers

#### CMSS 31092300 †1

Weatherproof Housing for maximum ten Drivers

#### Area Classification — (Stainless Steel, Clamp Cover)

NEMA/EEMAC Type 4, Type 4X, Type 12 and Type 13

UL50 Type 4, Type 4X

UL508 Type 4, Type 4X

CSA Type 4, Type 4X

IEC 529, IP66

#### CMSS 31092101 †1

Weatherproof Housing for maximum three Drivers

#### CMSS 31092201 †1

Weatherproof Housing for maximum six Drivers

#### CMSS 31092301 †1

Weatherproof Housing for maximum ten Drivers



#### Area Classification — (Stainless Steel) Continuous Hinge on one side, Clamps on other three sides of cover.

NEMA/EEMAC Type 4, Type 4X, Type 12 and Type 13

UL50 Type 4, Type 4X

UL508 Type 4, Type 4X

CSA Type 4, Type 4X

IEC 529, IP66

#### CMSS 31092103 †1

Weatherproof Housing for maximum three Drivers

#### CMSS 31092203 †1

Weatherproof Housing for maximum six Drivers

#### CMSS 31092303 †1

Weatherproof Housing for maximum ten Drivers

– NOTE –

Please refer to reference information in the back of this catalog for definitions, standards and cross references.

†1 If it is desired to order a housing with "NO HOLES" then add a "-NH" to the right of the model number, i.e. CMSS 31092100-NH.

# Weatherproof Housings For DIN-Rail Mount Drivers

## Weatherproof Housing Dimensions

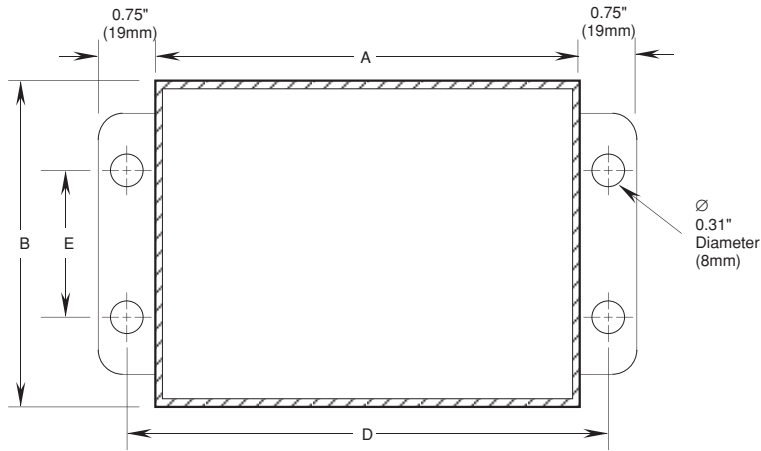

**- NOTE -**  
 Due to changes in housing manufacturer specifications, cover clamps may be located in positions other than depicted in these drawings.

## Clamp Style

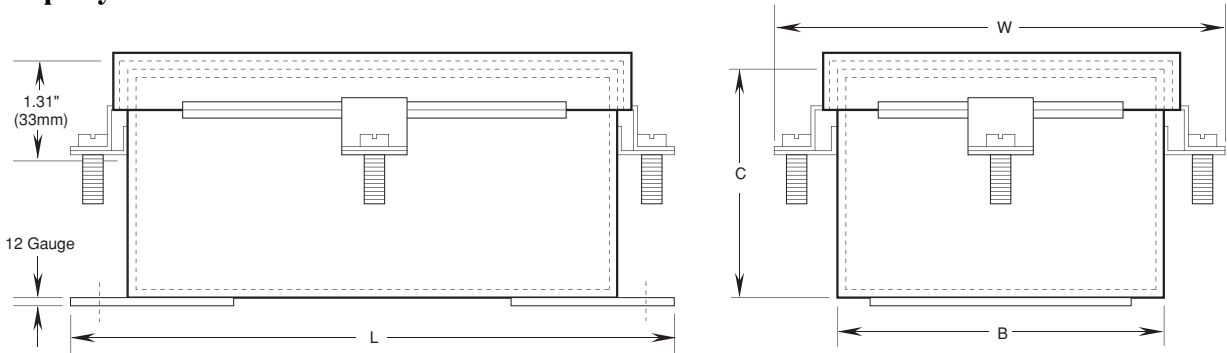

## Hinge Style

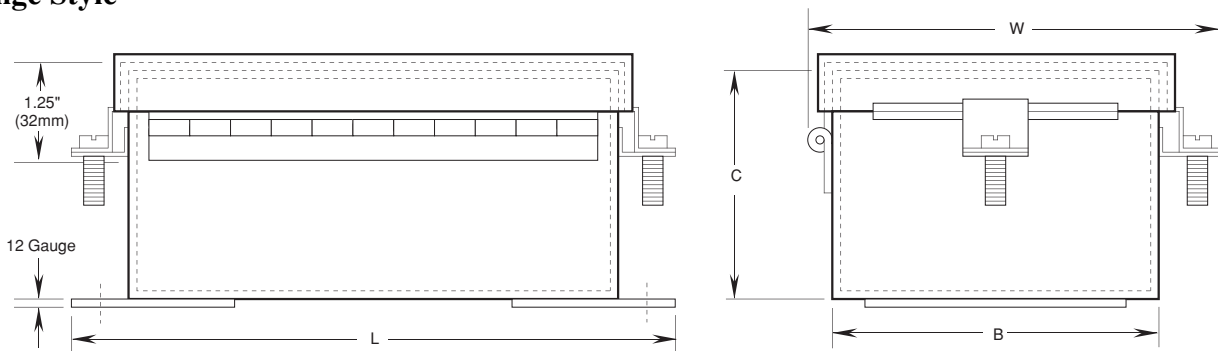

SKF Model Number	Box Size "A" x "B" x "C"	Mounting "D" x "E"	Clamp Style Overall "L" x "W"	Hinge Style Overall "L" x "W"
CMSS 31092100 CMSS 31092101 CMSS 31092103	8.00" x 6.00" x 3.50" (203mm x 152mm x 89mm)	8.75" x 4.00" (222mm x 102mm)	9.50" x 7.38" (241mm x 187mm)	9.50" x 6.94" (241mm x 176mm)
CMSS 31092200 CMSS 31092201 CMSS 31092203	10.00" x 8.00" x 4.00" (254mm x 203mm x 102mm)	10.75" x 6.00" (273mm x 152mm)	11.50" x 9.38" (292mm x 238mm)	11.50" x 8.94" (292mm x 227mm)
CMSS 31092300 CMSS 31092301 CMSS 31092303	12.00" x 10.00" x 5.00" (305mm x 254mm x 127mm)	12.75" x 8.00" (324mm x 203 mm)	13.50" x 11.38" (343mm x 289mm)	13.50" x 10.94" (343mm x 278mm)

## CMSS 601 Static Calibrator

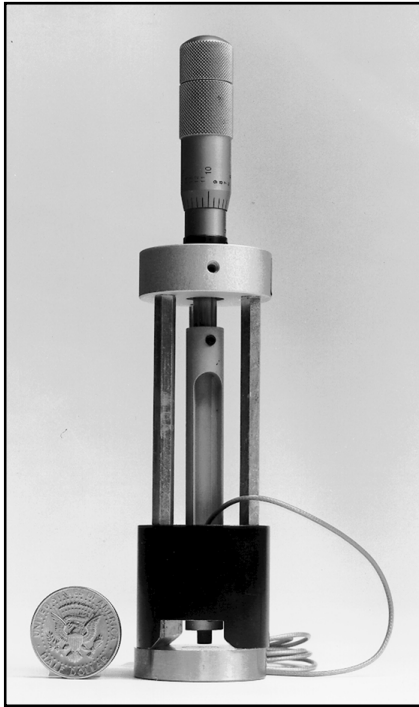

The CMSS 601 Field Calibrator provides a convenient, precise method for verifying the voltage output vs. gap of an Eddy Probe and Driver combination. It is especially useful for applications requiring exact calibration (the hot alignment of machinery) or where “targets” of various metal alloys are used.

As recommended by API Standard 670, the CMSS 601 can be used for calibrating an Eddy Probe on the actual shaft it will monitor. The Calibrator’s self-centering magnetic base holds the pickup rigidly at 90° to the shaft axis to provide reliable performance characteristics on its “real target.” The metal disc supplied with the Calibrator may be placed across the V-Shaped base as a standardized flat calibration target.



*The CMSS 601-1 is supplied as a portable kit complete with standard target disc, an Allen wrench and two adapters to accommodate both CMSS 65 and CMSS 68 Eddy Probes.*

### Precision Results ... Easy to Use

1. An Eddy Probe is locked into the proper size adapter with the set screw.
2. The adapter and probe cable are slipped upward through the magnetic base and over the micrometer spindle.
3. The magnetic base is placed on a machine shaft or on the target disc.
4. The probe lead is connected to a matching Eddy Probe Driver through an Extension Cable.
5. -24 Vdc is applied to the driver, whose output is connected to a voltmeter.
6. The micrometer spindle is set to read 40 mils.
7. The adapter and probe are vertically positioned to produce a -8 Vdc voltmeter reading and then locked in position on the micrometer spindle by the upper set screw. The unit is now ready for use.

To calibrate an Eddy Probe, the spindle is lowered by the micrometer head to a reading of 10 mils and a voltage reading taken. Readings are taken successively at 5 mil or 10 mil increments. Fine tuning is available with the calibrate potentiometer on the driver.

### Ordering Information

**CMSS 601-1** Standard (English units)

**CMSS 601-2** Metric Version (Metric units)

**CMSS 601-7** For long probe cases (over 2.0")\* (English units)

**CMSS 601-8** Metric Version for long probe cases (over 60mm)\* (Metric units)

\* Calibrators for long probes use integral target only ... will not observe actual shaft.

## CMSS 748-3 Probe Gapper

### Fast, Easy, Accurate . . .

To save time and money in the field, SKF Condition Monitoring offers a unique device — The CMSS 748-3 Probe Gapper, a portable, battery-powered unit for the SKF CMSS 65, and CMSS 68 Eddy Probes.

Whether you are on the factory floor, in a test cell or working on a machine in the plant, you can use the CMSS 748-3 for conveniently gapping a probe at 40 mils direct reading. (No conversion from volts is necessary as with a voltmeter.) Built-in signal conditioning allows a probe to be gapped with or without the extension cable, and there is never any need to wait for conduit runs and wiring to be installed back to the drivers and monitors.

Since the CMSS 748-3 stays “on” for a period of 4-5 minutes after the Power-On switch is pressed, the operator can use two hands to set and lock the probe in place.

### Specifications

**Probe *WITHOUT* CMSS 958 Compatibility:** CMSS 65 or CMSS 68 with 1 meter cable overall length.

**Probe *WITH* CMSS 958 Compatibility:** Any Probe and Extension Cable combination normally driven by a standard 5 meter CMSS 665 or CMSS 668 Series driver.

**Dimensions:** 2.4" (52mm) Height x 3.6" (103mm) Width x 9.3" (236mm) Length

**Weight:** 1.6 lb. (0.62 Kg)

**Batteries:** Four each 9V Transistor.

*Life approximate:* 10 – 12 hours continuous use.

– NOTE –

*40 mil reading only accurate with SKF CMSS 65 or CMSS 68 Eddy Current Probes observing 4140 steel or a similar metal.*



### Ordering Information

**CMSS 748-3** Standard for use with CMSS 65 or CMSS 68 Eddy Probes only.

# Typical Eddy Probe Arrangement Plans

## Turbine

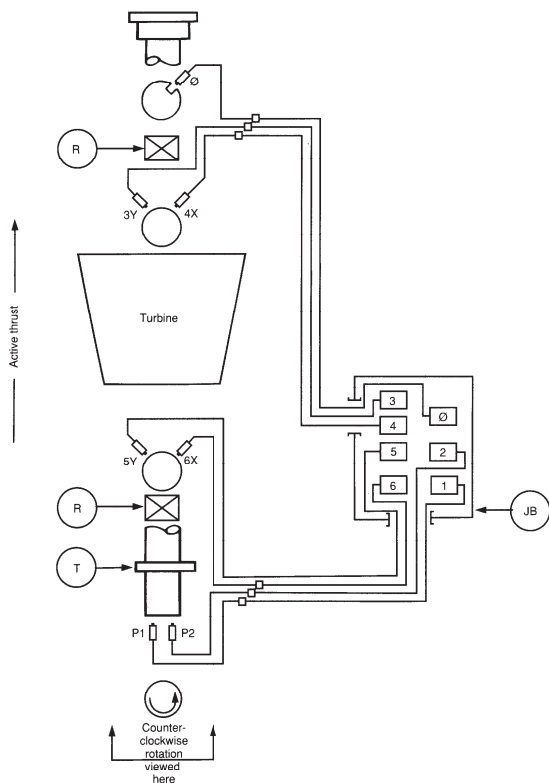

Item	Description
P1	Axial position probe (instrument manufacturer ID data).
P2	Axial position probe (instrument manufacturer ID data).
3Y	Low pressure end radial vibration probe, 45° off TDC (instrument manufacturer ID data).
4X	Low pressure end radial vibration probe, 45° off TDC (instrument manufacturer ID data).
5Y	High pressure end radial vibration probe, 45° off TDC (instrument manufacturer ID data).
6X	High pressure end radial vibration probe, 45° off TDC (instrument manufacturer ID data).
Ø	Phase reference probe, 45° off TDC (instrument manufacturer ID data).
R	Radial bearing (description)
T	Thrust bearing (description)
JB	Junction box

- NOTES:**
1. The numbering system shown is based on the higher pressure end equaling a higher device number.
  2. TDC = Top dead center.

## Compressor

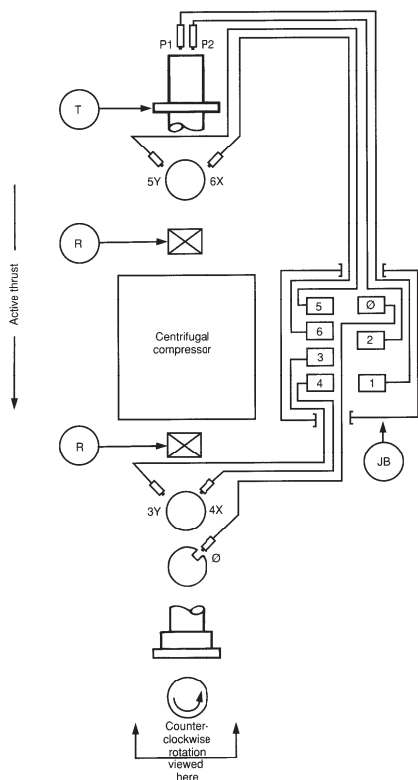

Item	Description
P1	Axial position probe (vendor and model number).
P2	Axial position probe (vendor and model number).
3Y	Low pressure end radial vibration probe, 45° off TDC (vendor and model number).
4X	Low pressure end radial vibration probe, 45° off TDC (vendor and model number).
5Y	High pressure end radial vibration probe, 45° off TDC (vendor and model number).
6X	High pressure end radial vibration probe, 45° off TDC (vendor and model number).
Ø	Phase reference probe, 45° right of TDC (vendor and model number).
R	Radial bearing (description)
T	Thrust bearing (description)
JB	Junction box (description)

- NOTES:**
1. TDC = Top dead center.



# Typical Eddy Probe Arrangement Plans

## Electric Motor

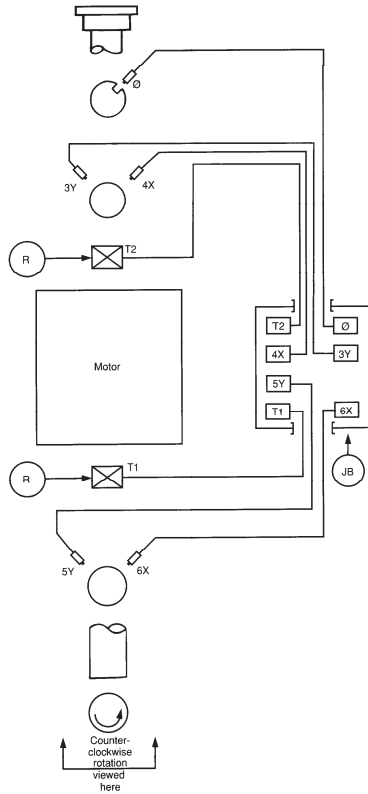

Item	Description
3Y	Coupling end Y radial vibration probe, 45° off TDC (instrument manufacturer ID data).
4X	Coupling end X radial vibration probe, 45° off TDC (instrument manufacturer ID data).
5Y	Outboard end Y radial vibration probe, 45° off TDC (instrument manufacturer ID data).
6X	Outboard end X radial vibration probe, 45° off TDC (instrument manufacturer ID data).
Ø	Phase reference probe, 45° off TDC (instrument manufacturer ID data).
T1	Outboard end bearing temperature.
T2	Coupling end bearing temperature.
R	Radial bearing (description)
JB	Junction box

NOTES: 1. TDC = Top dead center.

## Pump

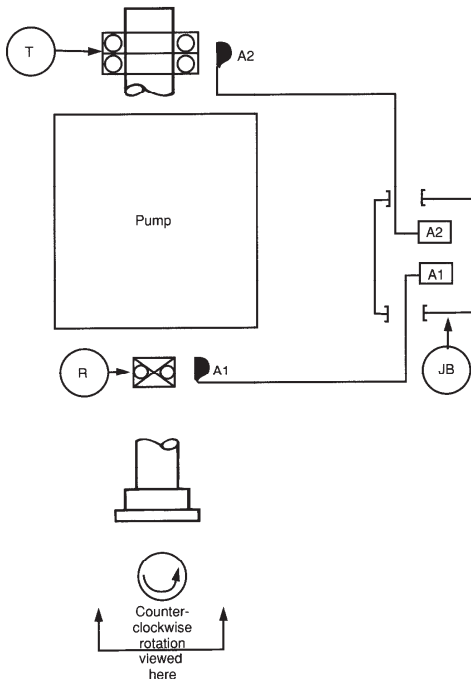

Item	Description
A1	Coupling end radial horizontal accelerometer, 90° off TDC (instrument manufacturer ID data).
A2	Outboard end radial horizontal accelerometer, 90° off TDC (instrument manufacturer ID data).
R	Radial bearing (description)
T	Thrust bearing (description)
JB	Junction box

NOTES: 1. TDC = Top dead center.

# Typical Eddy Probe Arrangement Plans

## Gear Box (Double Helical Gear)

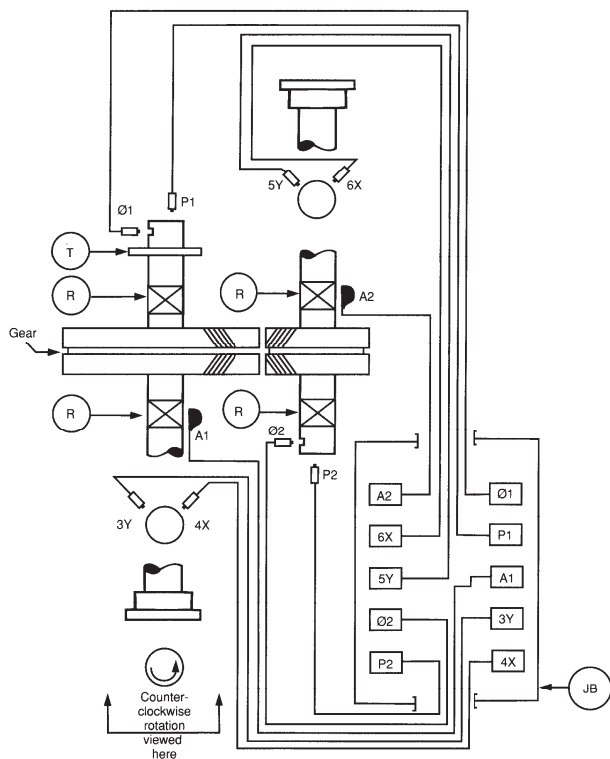

Item	Description
3Y	Input shaft coupling end Y radial vibration probe, 45° off TDC (instrument manufacturer ID data).
4X	Input shaft coupling end X radial vibration probe, 45° off TDC (instrument manufacturer ID data).
A1	Input shaft coupling end horizontal radial acceleration, 90° off TDC (instrument manufacturer ID data).
P1	Input shaft thrust bearing end axial position probe #1, (instrument manufacturer ID data).
A2	Output shaft coupling end horizontal radial acceleration, 90° off TDC (instrument manufacturer ID data).
5Y	Output shaft coupling end Y radial vibration probe, 45° off TDC (instrument manufacturer ID data).
6X	Output shaft coupling end X radial vibration probe, 45° off TDC (instrument manufacturer ID data).
Ø1	Input shaft noncoupling end phase reference probe at TDC (instrument manufacturer ID data).
Ø2	Output shaft noncoupling end phase reference probe at TDC (instrument manufacturer ID data).
P2	Output shaft thrust bearing end axial position probe #2 (instrument manufacturer ID data).
R	Radial bearing (description)
T	Thrust bearing (description)
JB	Junction box

- NOTES:**
1. TDC = Top dead center.
  2. Oscillator-demodulators and accelerometer signal conditioners should be located in separate junction boxes.
  3. For a single helical gear, a pair of axial probes should be installed at each thrust bearing end.

# Bearing Housing Mounting

End View

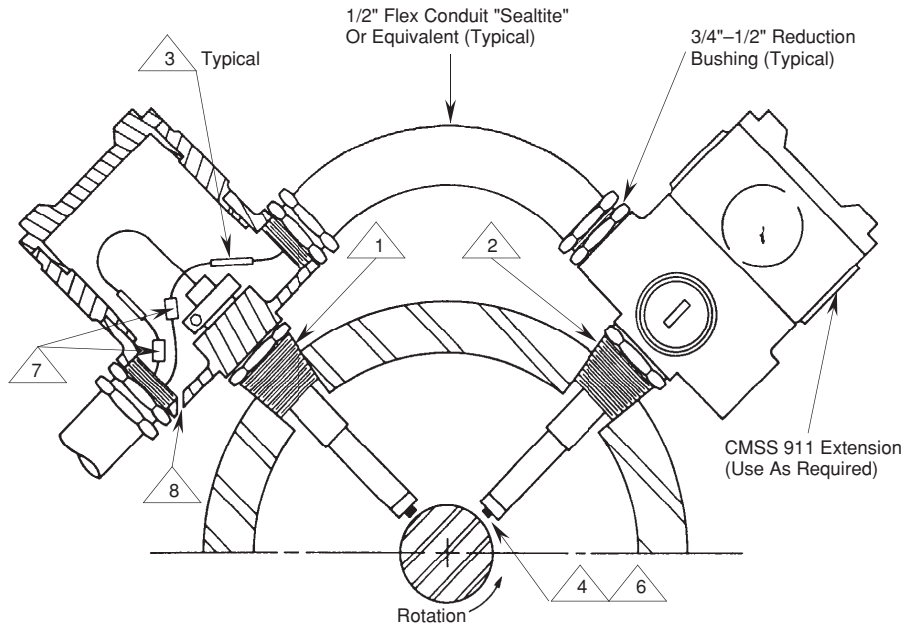

**Notes:**

- 1 Drill and tap housing for 3/4" NPT (typical).
- 2 Set sealing adapter tight in bearing housing before pulling lead wires.
- 3 Identify leads prior to installation. Use tag numbers as required.
- 4 Probes must be mounted perpendicular to shaft.
- 5 Do not pull thermocouple wire and probe lead wires into same outlet without Engineering Department approval.
- 6 Check gap Volts after CMSS 911 assembly has been installed. Set gap at  $-8.0 \pm 1/2$  Volts ( $40 \pm 2.5$  mils). May use SKF Condition Monitoring CMSS 748 Probe Gapper.
- 7 Torque mating connectors to  $145 \pm 5$  inch-ounces. Then wrap connections with Teflon tape (typical).
- 8 Drill 1/4" drain hole in lowest point of box (typical).

Side View

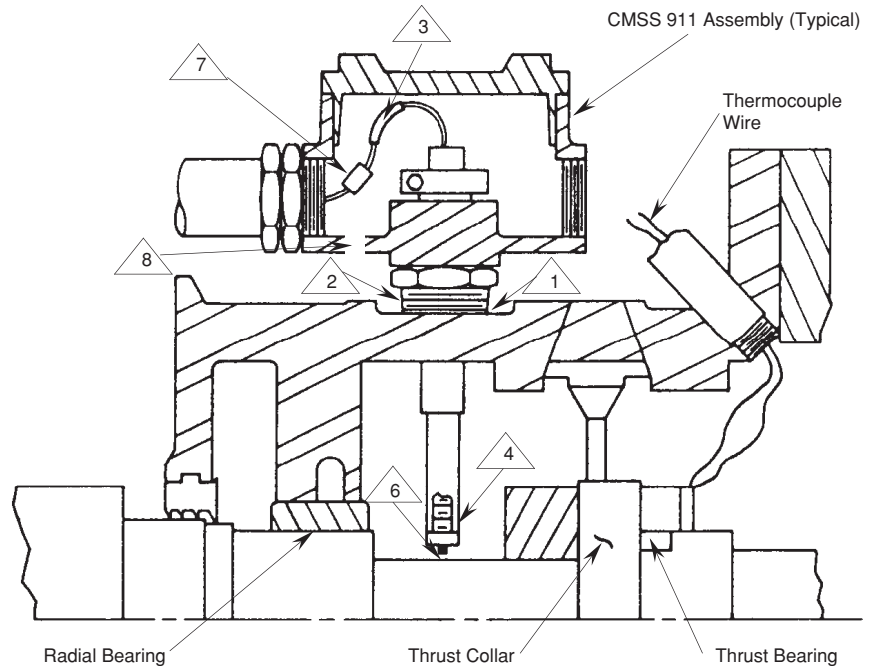

# Axial Probe Installation

## Thrust Probe Installation Recommendations

1. At least two probes per rotor are recommended.
2. Where the probes cannot be changed without shutting down the machine, install spare probes.
3. Calibrate probe, cable and driver and record final response curves for primary as well as spare probes. The SKF Condition Monitoring CMSS 601 Static Calibrator may be used.
4. Try to observe the thrust collar with one probe and the shaft with the other.
5. Probes must be mounted with in one foot of the thrust collar.
6. Avoid mounting probes through thin plates or bell housings that may bow with thermal expansion.
7. Determine the float zone of the rotor by jacking the rotor in both directions. Use up to 2 tons pressure.
8. Measure the rotor movement with dual indicators on the shaft, the Eddy Probe voltage change at the driver and the monitor reading. (All three should agree.)
9. Jack the shaft several times each way to verify readings.
10. Set the probe gap so that the center of the probe's range is in the center of the float zone.
11. Securely lock the probe and any adapters in place.
12. Be sure the probe tip has a side clearance of at least 0.200".

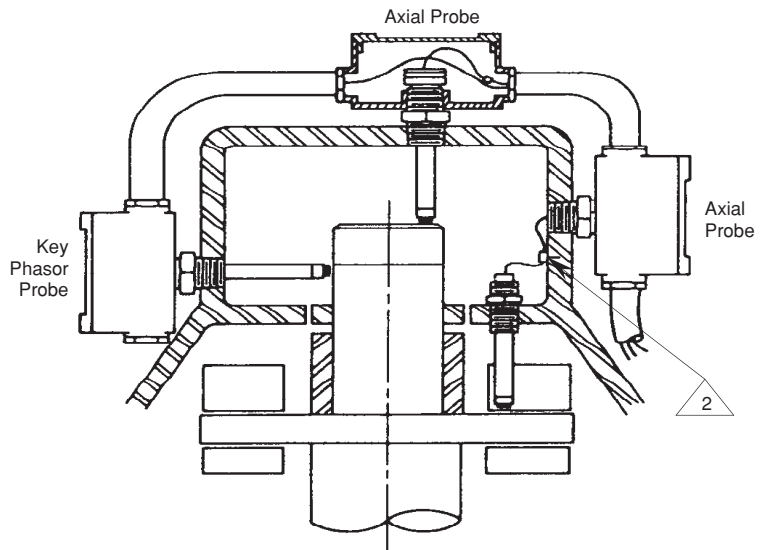
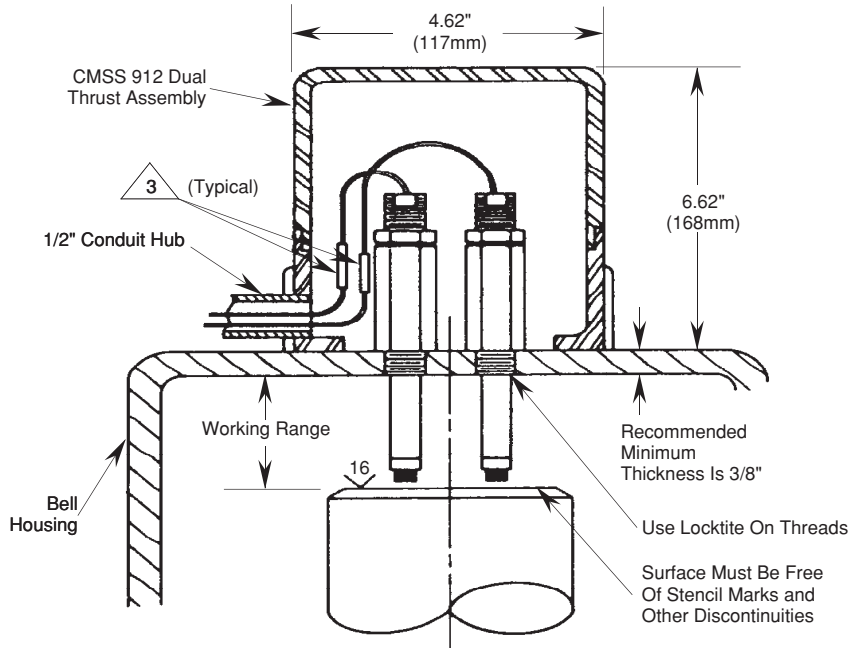

### Notes:

- |                                                                                                                                                                                                                                                                                                                                       |                                                                                                                                                                                                                                                            |                                                                                                                                                                                                    |
|---------------------------------------------------------------------------------------------------------------------------------------------------------------------------------------------------------------------------------------------------------------------------------------------------------------------------------------|------------------------------------------------------------------------------------------------------------------------------------------------------------------------------------------------------------------------------------------------------------|----------------------------------------------------------------------------------------------------------------------------------------------------------------------------------------------------|
| <p>1 Set sealing adapter tight in housing before pulling lead wires through.</p> <p>2 Probe lead wires must be secured against internal whipping and rubbing.</p> <p>3 Identify probe leads prior to installation. Use tag numbers as required.</p> <p>4 Probes must be mounted perpendicular to shaft or surface it is "seeing".</p> | <p>5 Do not pull thermocouple wires and probe lead wires into same outlet without engineering department approval.</p> <p>6 Check gap volts after CMSS 911 or CMSS 912 assemblies have been installed. Use CMSS 748 Probe Gapper or digital voltmeter.</p> | <p>7 Set gap at midpoint of probe range at the center of the shaft float zone.</p> <p>8 Torque mating connectors to <math>145 \pm 5</math> inch-ounces. Then wrap connectors with Teflon tape.</p> |
|---------------------------------------------------------------------------------------------------------------------------------------------------------------------------------------------------------------------------------------------------------------------------------------------------------------------------------------|------------------------------------------------------------------------------------------------------------------------------------------------------------------------------------------------------------------------------------------------------------|----------------------------------------------------------------------------------------------------------------------------------------------------------------------------------------------------|

# 5mm and 8mm Eddy Probe Outline Dimension Drawing

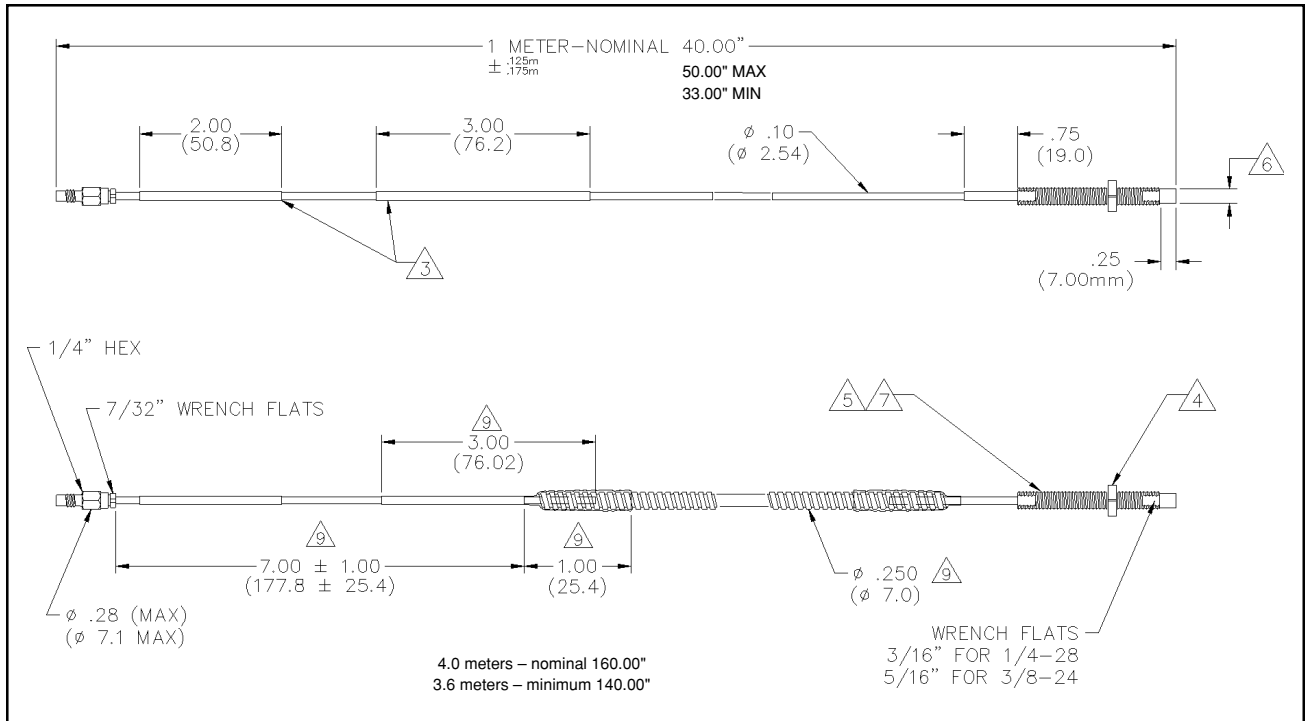

- 1 Cable shown with and without flex armor.
- 2 Drawing applicable to CMSS 65 and CMSS 68.
- 3 Clear shrink tubing for label identification.
- 4 7/16" for 1/4-28 thread probe case. (13mm for M8 x 1 thread probe case.)  
 9/16" for 3/8-24 thread probe case. (17mm for M10 x 1 thread probe case.)
- 5 Probe case length dependent on probe model number.

- 6 8mm (0.312") for CMSS 68.  
 5mm (0.200") for CMSS 65.
- 7 1/4-28 or 3/8-24 according to probe model number.
- 8 All information applies to both models unless otherwise specified.
- 9 Armored model only.
- 10 All dimensions in parentheses are millimeters (mm).



# 5mm and 8mm Eddy Probe Driver Outline Dimension Drawing

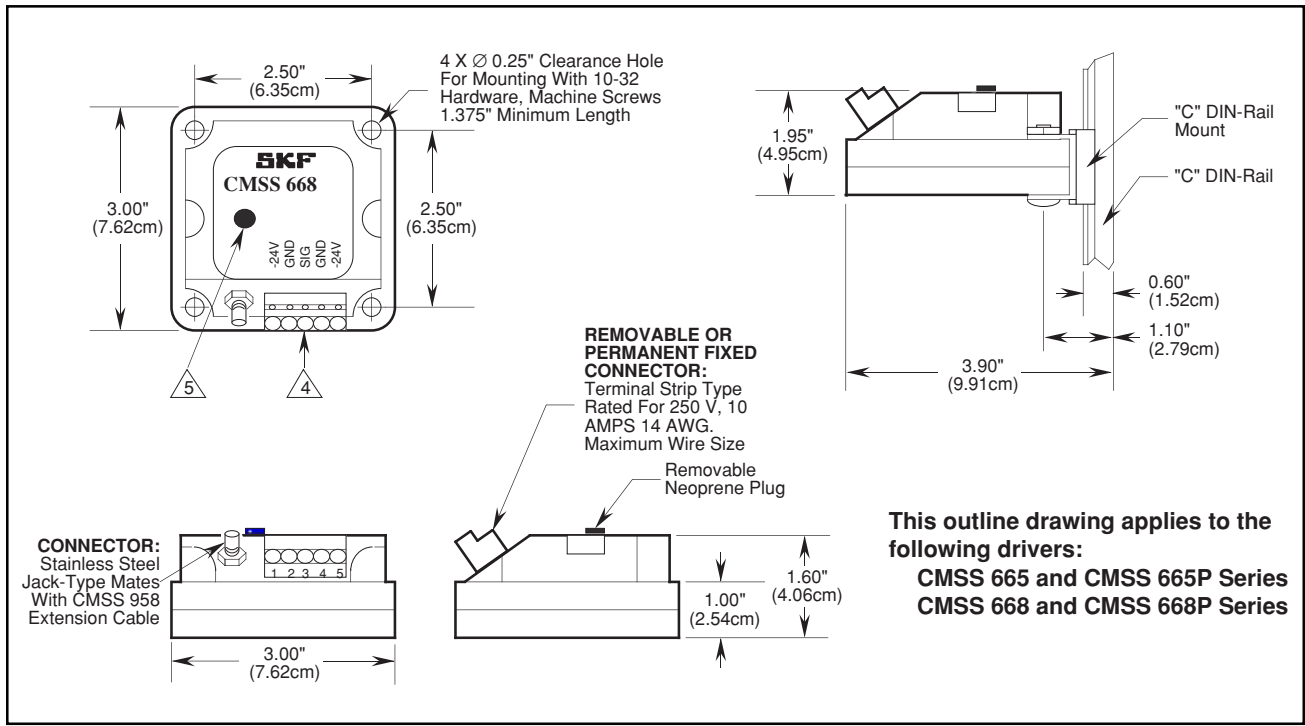

1 **Specifications:**

**Operating Temperature Range:** -30°F to +150°F (-35°C to +65°C)

2 **Storage:** -45°F to +150°F (-43°C to +65°C)

**Material:** Case made from RYTON®

3 Units interchangeable without recalibration.



4 Probe driver 5 terminal connector shown. Removable or permanent fixed connectors available.



5 Access hole for fine trimming of calibration on probe drivers or for range selection on transmitter units.

## CMSS 958 Extension Cable Outline Dimension Drawing

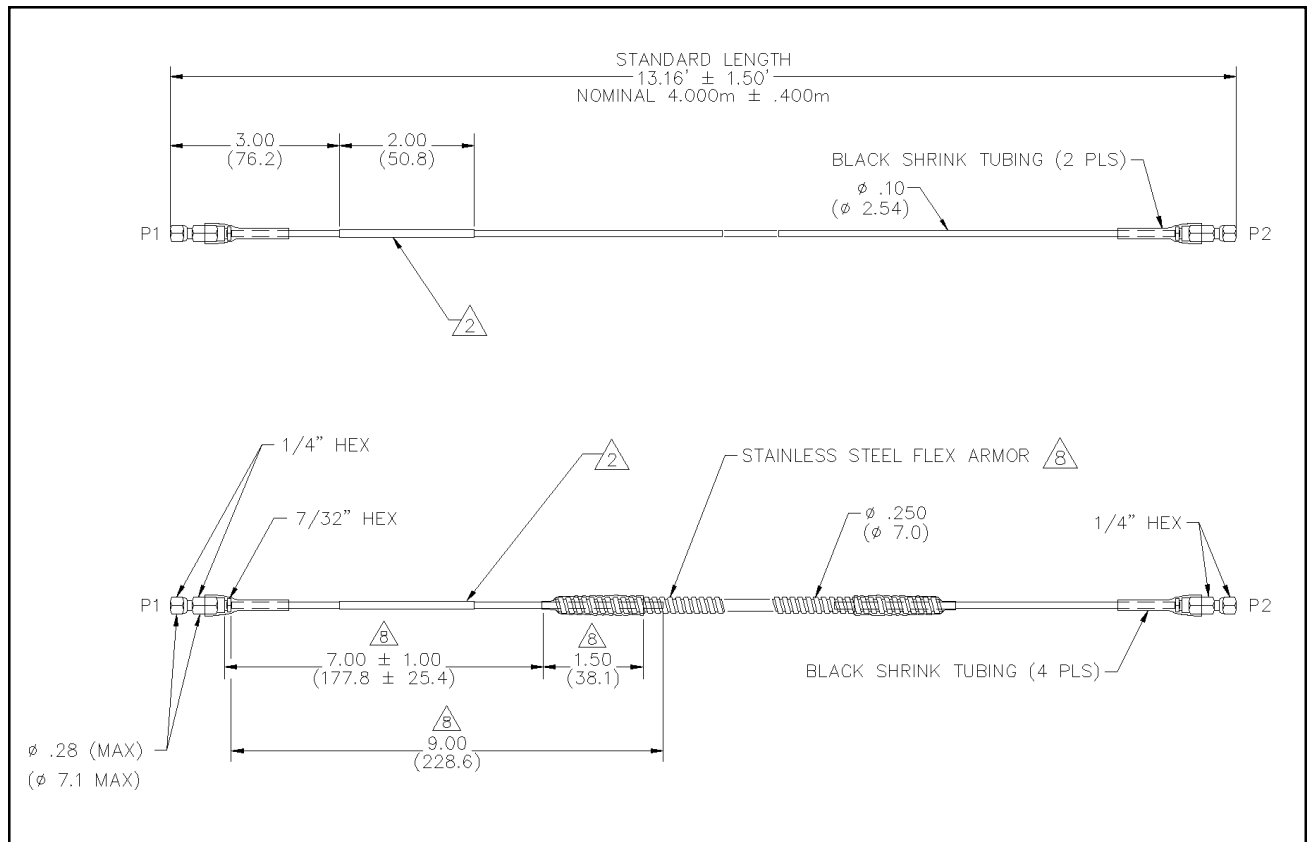

1 Cable shown with and without flex armor.

2 Clear shrink tubing for label identification.

3 **Specifications:**

**Operating Temperature Range:** -30°F to +250°F  
(-35°C to +120°C)

**Storage:** -45°F to +250°F (-43°C to +120°C)

4 Bend radius 1.375" (34.9mm) minimum (Armored).  
Bend radius 0.750" (19.0mm) minimum (Non-Armored).

5 High strength steel coax with steel braid shield.

6 Installation direction not restricted (Reversible).

7 Information applies to both models unless otherwise specified.

8 Armored model only.

9 All dimensions in parentheses are millimeters (mm).

## CE Mark



## Hazardous Area Information

European Community Declaration of Conformity.

**Manufacturer:**

SKF Condition Monitoring

4141 Ruffin Road

San Diego, California USA

**Product:** SKF Eddy Current Probe Systems

SKF Condition Monitoring, Inc. of San Diego, California USA hereby declares, that the referenced product, to which this declaration relates, is in conformity with the provisions of:

Council Directive 89/336/EEC (3 May 1989), on the Approximation of the Laws of the Member States Relating to Electromagnetic Compatibility, as amended by:

Council Directive 92/31/EEC (28 April 1992);

Council Directive 93/68/EEC (22 July 1993).

The above-referenced product complies with the following standards and/or normative documents:

EN 50081-2, Electromagnetic compatibility—Generic emission standard. Part 2: Industrial environment (August 1993).

EN 50082-2, Electromagnetic compatibility—Generic immunity standard. Part 2: Industrial

**Area General Information**

Review the Hazardous Location Information section to properly define the area in which the sensors and monitoring systems are to be installed, then determine which equipment will meet the specified requirements.

Sensors may either be installed in a Class 1, Division 1 (Zone 0, 1) or a Division 2 (Zone 2) hazardous area. However, for installation in these areas, the sensors must be approved by an appropriate agency.

SKF Condition Monitoring does have eddy probe sensor systems approved for installation in these areas and specific model numbers assigned to easily identify these agency approved options.

It is strongly recommended that intrinsic safety barriers be used for the hazardous area installations as the means of limiting the thermal and electrical energy to the sensor components in Class 1, Division 1 (Zone 0, 1) and Division 2 (Zone 2) hazardous areas. The agency approved intrinsic safe sensor components, and the intrinsic safety barriers provide for a very high level of safety, and aid in the prevention of fire and explosions in your facility.

It is recommended in field installations, that housings be used to provide physical protection for the SKF Condition Monitoring Eddy Probe Drivers. For CENELEC approved systems, these housing should have a minimum rating of IP20. Other agency approvals do not specify a level of protection for the housings.

However SKF does provide a series of standard housings which can be used for these installations.

**Agency Approvals**

SKF Condition Monitoring has obtained agency approvals from the following:

**British Approvals Service for Electrical Equipment in Flammable Atmospheres – EECS (BASEEFA)**

EECS (BASEEFA) intrinsically safe certified equipment is intended for use in Zone 0, 1 as intrinsically safe in accordance with CENELEC European harmonized Standards, [EN50 014 (1977) and EN50 020 (1977)] and is accepted by member countries of Austria, Belgium, Denmark, Finland, France, Germany, Greece, Ireland, Italy, Luxembourg, the Netherlands, Norway, Portugal, Spain, Sweden, Switzerland, and the United Kingdom.

**Canadian Standards Association – CSA**

CSA intrinsically safe certified equipment is intended for use in Class 1, Division 1, Groups A, B, C, D.

**Factory Mutual Research, USA – FM**

**Approved**  
FM

FM intrinsically safe and non-incendive certified equipment is intended for use in Class 1, Division 1 and Division 2, Groups A, B, C, D.

**To order eddy probe systems with the various agency approvals** please refer to the front part of the catalog under the specific eddy probe model number desired i.e. CMSS 65 or CMSS 68 systems. There is an options form available which delineates the specific agency approval desired. Select the appropriate agency approval and the additional configuration requirements for the eddy probe and extension cable. Then select the appropriate driver model number indicated on the pages following.

## Intrinsic Safety (I-S) Barriers for Use With CMSS 65 and CMSS 68 Series Eddy Probe Systems

The following information provides a listing of the Intrinsic Safety Barriers used by the various testing agencies during the eddy probe approval process. As such these barriers meet the various agency approvals and allow for the proper operation of the SKF Condition Monitoring Eddy Probe Systems when properly installed in the hazardous areas. Also included are the parameters for selecting other manufacturers barriers.

However, only the brand named barriers listed have been tested and are verified to work properly with the CMSS 65 and CMSS 68 eddy probe systems.

### Factory Mutual – (FM)



Intrinsically safe for Class 1, Division 1, Groups A, B, C, D

#### Entity Parameters:

##### Supply terminals:

$V_{max} = 30$  Vdc,  
 $I_{max} = 245$  mA,  
 $C_i = 0.056$  microfarad,  
 $L_i = 0.536$  millihenries.

##### Signal terminals:

$V_{max} = 24$  Vdc,  
 $I_{max} = 60$  mA,  
 $C_i = 0$  microfarad,  
 $L_i = 0$  millihenries

SKF Condition Monitoring drawing number 31187500 is applicable.

#### System Approval:

##### Barriers:

**Power:** Stahl 8901/30-280/085/00

**Signal:** Stahl 8901/30-199/038/00

Barriers are approved by FM, CSA, and PTB, CESI (CENELEC Standard)

SKF Condition Monitoring drawing number 31163200 is applicable.

– CAUTION –

*All intrinsic safety installations should be done in accordance with the national installation codes of practice for the particular country at the place of installation.*

### Canadian Standards Association – CSA



Intrinsically safe for Class 1, Division 1, Groups A, B, C, D

#### System Approval:

##### Barriers:

**Power:** Stahl 8901/30-280/085/00

**Signal:** Stahl 8901/30-199/038/00

Barriers are approved by FM, CSA, and PTB, CESI (CENELEC Standard)

SKF Condition Monitoring drawing number 31163300 is applicable

**Power/Signal:** MTL 796 Dual (neg)

Measurement Technology Ltd., (MTL)

SKF Condition Monitoring drawing number 31163200 is applicable.

– CAUTION –

*All intrinsic safety installations should be done in accordance with the national installation codes of practice for the particular country at the place of installation.*

### British Approvals Service for Electrical Equipment in Flammable Atmospheres – EECS (BASEEFA) (CENELEC Standard)



Intrinsic safe code (see below)

#### System Approval:

Intrinsic safe code EEx ia IIC T2

SKF Condition Monitoring drawing number 31451400 is applicable.

#### Eddy Probe Approval:

Intrinsic safe code EEx ia IIC T2 (Tamb = +100°C)

#### Driver Approval:

Intrinsic safe code EEx ia IIC T4 (Tamb = +75°C)

$U_{max:in} = 28$  Vdc,

$I_{max:in} = 138$  mAdc,

$W_{max:in} = 1.0$  W

$C_{eq} = 0.06$  microfarad,

$L_{eq} = 0.5$  millihenries

#### Suggested Barriers:

**Power:** Stahl 9003/50-200/050

**Signal:** Stahl 8901/34-280/000/60

Barriers are approved by EECS (BASEEFA) (CENELEC Standard).

**Power/Signal:** MTL796 Dual (neg)

Measurement Technology Ltd., (MTL).

Barriers are approved by EECS (BASEEFA) (CENELEC Standard).

– CAUTION –

*All intrinsic safety installations should be done in accordance with the national installation codes of practice for the particular country at the place of installation.*

## Classes and Divisions

Hazardous locations are those areas where a potential for explosion and fire exist because of flammable gases, vapors or finely pulverized dusts in the atmosphere, or because of the presence of easily ignitable fibers or flyings. Hazardous locations may result from the normal processing of certain volatile chemicals, gases, grains, etc., or they may result from accidental failure of storage systems for these materials. It is also possible that a hazardous location may be created when volatile solvents or fluids, used in a normal maintenance routine, vaporize to form an explosive atmosphere.

Regardless of the cause of a hazardous location, it is necessary that every precaution be taken to guard against ignition of the atmosphere. Certainly no open flames would be permitted in these locations, but what about other sources of ignition?

### Electrical Sources of Ignition

A source of ignition is simply the energy required to touch off an explosion in a hazardous location atmosphere.

Electrical equipment such as lighting fixtures and motors are classified as "heat producing," and they will become a source of ignition if they reach a surface temperature which exceeds the ignition temperature of the particular gas, vapor or dust in the atmosphere.

It is also possible that an abnormality or failure in an electrical system could provide a source of ignition. A loose termination in a splice box or a loose lamp in a socket can be the source of both arcing and heat. The failure of insulation from cuts, nicks or aging can also act as an ignition source from sparking, arcing and heat.

### Hazardous Locations and the National Electrical Code®\*

The National Electrical Code® treats installations in hazardous locations in articles 500 through 517.

Each hazardous location can be classified by the definitions in the NEC. Following are interpretations of these classifications and applications.

#### CLASS I LOCATIONS

Class I locations are those in which flammable gases or vapors are or may be present in the air in quantities sufficient to produce explosive or ignitable mixtures.

##### Class I, Division 1

These are Class I locations where the hazardous atmosphere is expected to be present during normal operations. It may be present continuously, intermittently, periodically or during normal repair or maintenance operations. Division 1 locations are also those locations where a breakdown in the operation of processing equipment results in the release of hazardous vapors and the simultaneous failure of electrical equipment.

##### Class I, Division 2

These are Class I locations in which volatile flammable liquids or gases are handled, processed or used, but in which they will normally be confined within closed containers or closed systems from which they can escape only in the case of accidental rupture or breakdown of the containers or systems. The hazardous conditions will occur only under abnormal conditions.

#### CLASS II LOCATIONS

Class II locations are those that are hazardous because of the presence of combustible dust.

##### Class II, Division 1

These are Class II locations where combustible dust may be in suspension in the air under normal conditions in sufficient quantities to produce explosive or ignitable mixtures. This may occur continuously, intermittently or periodically. Division 1 locations also exist where failure or malfunction of machinery or equipment might cause a hazardous location to exist while providing a source of ignition with the simultaneous failure of electrical equipment. Included also are locations in which combustible dust of an electrically conductive nature may be present.

##### Class II, Division 2

A Class II, Division 2 location is one in which combustible dust will not normally be in suspension in the air and normal operations will not put the dust in suspension, but where accumulation of the dust may interfere with the safe dissipation of heat from electrical equipment or where accumulations near electrical equipment may be ignited by arcs, sparks or burning material from the equipment.

#### CLASS III LOCATIONS

Class III locations are those that are hazardous because of the presence of easily ignitable fibers or flyings, but in which the fibers or flying are not likely to be in suspension in the air in quantities sufficient to produce ignitable mixtures.

##### Class III, Division 1

These are locations in which easily ignitable fibers or materials producing combustible flyings are handled, manufactured or used.

##### Class III, Division 2

These locations are where easily ignitable fibers are stored or handled.

\* All references to the National Electric Code® are from the NFPA 70 1990 Edition.

## Classes and Divisions

### Hazardous Location Equipment

#### *CLASS I LOCATION EQUIPMENT*

Devices for Class I locations are housed in enclosures which are designed to be strong enough to contain an explosion if the hazardous vapors enter the enclosure and are ignited. These enclosures then cool and vent the products of combustion in such a way that the surrounding atmosphere is not ignited.

Heat producing equipment for hazardous locations must also be designed to operate with surface temperatures below the ignition temperatures of the hazardous atmosphere.

Since the different vapors and gases making up hazardous atmospheres have varying properties, they have been placed in groups based on common flame propagation characteristics and explosion pressures. These groups are designated A, B, C, and D, and the equipment selected must be suitable for the group of the specific hazardous gas or vapor, with regard to flame propagation, explosion pressures and operating temperatures.

Reference to the National Electrical Code® will indicate that most of the equipment used for Class I Division 2 applications is the same as that used for Division 1 applications.

#### *CLASS II LOCATION EQUIPMENT*

The enclosures used to house devices in Class II locations are designed to seal out dust. Contact between the hazardous atmosphere and the source of ignition has been eliminated and no explosion can occur within the enclosure.

As in Class I equipment, heat producing equipment must be designed to operate below the ignition temperature of the hazardous atmosphere. However, in Class II equipment, additional consideration must be given to the heat buildup which may result from the layer of dust which will settle on the equipment.

Dusts have also been placed in Groups designated E, F, and G, based on their particular hazardous characteristics and the dusts' electrical resistivity. It is important to select equipment suitable for the specific hazardous group.

#### *CLASS III LOCATION EQUIPMENT*

Class III locations require equipment which is designed to prevent the entrance of fibers and flyings, prevent the escape of sparks or burning material and operate at a temperature below the point of combustion.

### Hazardous Location Equipment Applications

Hazardous location equipment may be required in any area where the presence of flammable gases, vapors or finely pulverized dusts in the atmosphere is sufficient to create a threat of explosion or fire. It may also be required where easily ignitable fibers or flyings are present. The following is a representative (but hardly complete) list of the types of locations and operations requiring hazardous location equipment in at least certain areas.

#### *CLASS I LOCATIONS*

- Petroleum refining facilities
- Dip tanks containing flammable or combustible liquids
- Dry cleaning plants
- Plants manufacturing organic coatings
- Spray finishing areas (residue must be considered)

- Petroleum dispensing areas
- Solvent extraction plants
- Plants manufacturing or using pyroxylin (nitrocellulose) type and other plastics (Class II also)
- Locations where inhalation anesthetics are used
- Utility gas plants, operations involving storage and handling of liquefied petroleum and natural gas
- Aircraft hangers and fuel servicing areas

#### *CLASS II LOCATIONS*

- Grain elevators and bulk handling facilities
- Manufacture and storage of magnesium
- Manufacture and storage of starch
- Fireworks manufacture and storage
- Flour and feed mills
- Areas for packaging and handling of pulverized sugar and cocoa
- Facilities for the manufacture of magnesium and aluminum powder
- Some coal preparation plants and coal handling facilities
- Spice grinding plants
- Confectionery manufacturing plants

#### *CLASS III LOCATIONS*

- Wood working plants
- Textile mills
- Cotton gins and cotton seed mills
- Flax producing plants



## Chemical By Groups

### Group A – Atmospheres

- acetylene

### Group B – Atmospheres

- acrolein (inhibited)
- butadiene
- ethylene oxide
- formaldehyde (gas)
- hydrogen
- manufactured gases containing more than 30% hydrogen (by volume)
- propylene oxide
- propyl nitrate

### Group C – Atmospheres

- acetaldehyde
- allyl alcohol
- butyl mercaptan
- n-butyraldehyde
- carbon monoxide
- crotonaldehyde
- dicyclopentadiene
- diethyl ether
- diethylamine
- di-isopropylamine
- dimethylamine
- 1, 4-dioxane
- di-n-propylamine
- epichlorohydrin
- ethylene
- ethylenimine
- ethyl mercaptan
- n-ethyl morpholine
- hydrogen cyanide
- hydrogen selenide
- hydrogen sulfide
- isobutyraldehyde
- isopropyl glycidyl ether
- methylacetylene
- methylacetylene-propadiene (stabilized)
- methyl ether
- methyl formal
- methyl mercaptan
- monomethyl hydrazine
- morpholine
- nitroethane
- nitromethane
- 2-nitropropane
- propionaldehyde
- n-propyl ether
- tetrahydrofuran
- triethylamine
- unsymmetrical dimethyl hydrazine (UDMH 1, 1-dimethyl hydrazine)
- valeraldehyde

### Group D – Atmospheres

- acetic acid (glacial)
- acetone
- acetonitrile
- acrylonitrile
- allyl chloride
- ammonia
- n-amyl acetate
- sec-amyl acetate
- benzene
- butane
- 1-butanol (butyl alcohol)
- 2-butanol(secondary butyl alcohol)
- n-butyl acetate
- sec-butyl acetate
- butylamine
- butylene
- chlorobenzene
- chloroprene
- cyclohexane
- cyclohexene
- cyclopropane
- 1, 1-dichloroethane
- 1, 2-dichloroethylene
- 1, 3-dichloropropene
- di-isobutylene
- ethane
- ethanol (ethyl alcohol)
- ethyl acetate
- ethyl acrylate (inhibited)
- ethylamine
- ethyl benzene
- ethyl chloride
- ethylenediamine (anhydrous)
- ethylene dichloride
- ethylene glycol monomethyl ether
- ethyl formate
- gasoline
- heptane
- heptene
- hexane
- 2-hexanone
- hexenes
- isoamyl acetate
- isoamyl alcohol
- isobutyl acrylate
- isoprene
- isopropyl acetate
- isopropylamine
- isopropyl ether
- liquefied petroleum gas
- mesityl oxide
- methane (nature gas)
- methanol (methyl alcohol)
- methyl acetate
- methyl acrylate
- methylamine
- methylcyclohexane
- methyl ethyl ketone
- methyl formate
- methyl isobutyl ketone
- methyl isocyanate
- methyl methacrylate

### Group D – Atmospheres

- 2-methyl-1-propanol (isobutyl alcohol)
- 2-methyl-2-propanol (tertiary butyl alcohol)
- naphtha (petroleum)
- nonane
- nonene
- octane
- octene
- pentane
- 1-pentanol (amyl alcohol)
- 2-pentanone
- 1-pentene
- petroleum naphtha
- propane
- 1-propanol (propyl alcohol)
- 2-propanol (isopropyl alcohol)
- n-propyl acetate
- propylene
- propylene dichloride
- propylene oxide
- pyridine
- styrene
- toluene
- tripropylamine
- turpentine
- vinyl acetate
- vinyl chloride
- vinylidene chloride
- xylenes

### Group E – Atmospheres

Atmospheres containing combustible metal dusts regardless of resistivity, or other combustible dusts of similarly hazardous characteristics having resistivity of less than 105 ohm-centimeter.

### Group F – Atmospheres

Atmospheres containing carbon black, charcoal, coal or coke dusts which have more than 8 percent total volatile material (carbon black per ASTM D1620; charcoal, coal and coke dusts per ASTM D271) or atmospheres containing these dusts sensitized by other materials so that they present an explosion hazard, and having resistivity greater than 102 ohm-centimeter but equal to or less than 108 ohm-centimeter.

### Group G – Atmospheres

Atmospheres containing combustible dusts having resistivity of 105 ohm-centimeter or greater.

## Hazardous Locations Cross Reference

*Comparison of "Zones" to North America "Division" and the types of Protection Accepted*

IEC		North America	
Zone 0	Intrinsically safe apparatus of category ia or other apparatus, both specifically approved for Zone 0.	Class I, Division 1	Some users recognize the Zone 0 principle without using the name and would only install apparatus suitable for Zone 0 operation in such areas.
Zone 1	All equipment certified for Zone 0  Apparatus with type(s) of protection: <ul style="list-style-type: none"> <li>• "d" flameproof enclosure</li> <li>• "p" pressurized apparatus</li> <li>• "i" intrinsic safety (ia and ib)</li> <li>• "o" oil immersion</li> <li>• "e" increased safety</li> <li>• "q" powder filling</li> <li>• "s" special protection</li> </ul> In Future <ul style="list-style-type: none"> <li>• "m" moulding</li> </ul>		Apparatus with type(s) of protection: <ul style="list-style-type: none"> <li>• explosion proof enclosures</li> <li>• purging</li> <li>• intrinsic safety</li> <li>• oil immersion</li> </ul>
Zone 2	All equipment certified for Zone 0 or 1  Apparatus with type of protection: <ul style="list-style-type: none"> <li>• "n" nonsparking/nonincendive</li> </ul>	Class I, Division 2	All equipment certified for Division 1  Apparatus incapable of creating sparks or hot surfaces capable of ignition in "general purpose" enclosures, ANSI/ISA-S12.12-1986*

\* "Electrical Equipment for use in Class I, Division 2 Hazardous (Classified) Locations"

### Industry Reference Information

#### What's In A Rating?

As a way of standardizing enclosure performance, organizations like NEMA, UL, CSA, IEC, and TUV Rheinland use rating systems to identify an enclosure's ability to repel the outside environment. Resistance to everything from dripping liquid to hose down to total submersion is defined by the ratings system.

While these ratings are all intended to provide information to help you make a safer, more informed product choice, there are differences between them. NEMA, UL, and CSA are the organizations most commonly referred to in North America. Their ratings are based on similar application descriptions and expected performance. UL and CSA both require enclosure testing by qualified evaluators in their labs. They also send site inspectors to make sure a manufacturer adheres to prescribed manufacturing methods and material specification. NEMA, on the other hand, does not require independent testing and leaves compliance completely up to the manufacturer.

In Europe, TUV-IEC ratings are based on test methods, that are similar to UL and CSA. Nevertheless, there are differences in how enclosure performance is interpreted. For example, UL and CSA test requirements specify that even a single drop of water entering an enclosure is considered a test failure. In the IEC standards for each protection level (IP) a certain amount of water is allowed to enter the enclosure.

North American enclosure rating systems also include a 4X rating that indicates resistance to corrosion. This rating is

based on the enclosure's ability to withstand prolonged exposure to salt water spray.

While a 4X rating is a good indicator that an enclosure can resist corrosion, it does not provide information on how a specific corrosive agent will affect a given enclosure material.



### Comparison of Specific Non-Hazardous Applications

#### Outdoor Locations

Provides a Degree of Protection Against the Following Environmental Conditions	Type Of Enclosure	
	4	4X
Incidental Contact With The Enclosed Equipment	◆	◆
Rain, Snow, and Sleet*	◆	◆
Sleet		
Windblown Dust	◆	◆
Hosedown	◆	◆
Corrosive Agents		◆
Occasional Temporary Submersion		
Occasional Prolonged Submersion		

\* External operating mechanisms are not required to be operable when the enclosure is ice covered

## Enclosures For Non-Hazardous Locations

Type Designation	<b>NEMA</b> NEMA National Electrical Manufacturers Association (NEMA Standard 250) and Electrical and Electronic Manufacturers Association of Canada (EEMAC)	 Underwriters Laboratories Inc. (UL 50 and UL 508)	 Canadian Standards Association (Standard C22.2 Number 94)
<b>1</b>	Enclosures are intended for indoor use primarily to provide a degree of protection against contact with the enclosed equipment or locations where unusual service conditions do not exist.	Indoor use primarily to provide protection against contact with the enclosed equipment and against a limited amount of falling dirt.	General purpose enclosure. Protects against accidental contact with live parts.
<b>2</b>	Enclosures are intended for indoor use primarily to provide a degree of protection against limited amounts of falling water and dirt.	Indoor use to provide a degree of protection against limited amounts of falling water and dirt.	Indoor use to provide a degree of protection against dripping and light splashing of noncorrosive liquids and falling dirt.
<b>3</b>	Enclosures are intended for outdoor use primarily to provide a degree of protection against windblown dust, rain, and sleet; undamaged by the formation of ice on the enclosure.	Outdoor use to provide a degree of protection against windblown dust and windblown rain; undamaged by the formation of ice on the enclosure.	Indoor or outdoor use; provides a degree of protection against rain, snow, and windblown dust; undamaged by the external formation of ice on the enclosure.
<b>3R</b>	Enclosures are intended for outdoor use primarily to provide a degree of protection against falling rain and sleet; undamaged by the formation of ice on the enclosure.	Outdoor use to provide a degree of protection against falling rain, undamaged by the formation of ice on the enclosure.	Indoor or outdoor use; provides a degree of protection against rain and snow, undamaged by the external formation of ice on the enclosure.
<b>4</b>	Enclosures are intended for indoor or outdoor use primarily to provide a degree of protection against windblown dust and rain, splashing water, and hose-directed water; undamaged by the formation of ice on the enclosure.	Either indoor or outdoor use to provide a degree of protection against falling rain, splashing water, and hose-directed water; undamaged by the formation of ice on the enclosure; resists corrosion.	Indoor or outdoor use; provides a degree of protection against rain, snow, windblown dust, splashing and hose-directed water; undamaged by the external formation of ice on the enclosure.
<b>4X</b>	Enclosures are intended for indoor or outdoor use primarily to provide a degree of protection against corrosion, windblown dust and rain, splashing water, and hose-directed water; undamaged by the formation of ice on the enclosure.	Either indoor or outdoor use to provide a degree of protection against falling rain, splashing water, and hose-directed water; undamaged by the formation of ice on the enclosure; resists corrosion.	Indoor or outdoor use; provides a degree of protection against rain, snow, windblown dust, splashing and hose-directed water; undamaged by the external formation of ice on the enclosure; resists corrosion.
<b>6</b>	Enclosures are intended for use indoors or outdoors where occasional submersion is encountered.	Indoor or outdoor use to provide a degree of protection against entry of water during temporary submersion at a limited depth; undamaged by the formation of ice on the enclosure.	Indoor or outdoor use; provides a degree of protection against the entry of water during temporary submersion at a limited depth; undamaged by the external formation of ice on the enclosure; resists corrosion.
<b>12</b>	Enclosures are intended for indoor use primarily to provide a degree of protection against dust, falling dirt, and dripping non-corrosive liquids.	Indoor use to provide a degree of protection against dust, dirt, fiber flyings, dripping water, and external condensation of non-corrosive liquids.	Indoor use; provides a degree of protection against circulating dust, lint, fibers, and flyings; dripping and light splashing of non-corrosive liquids; not provided with knockouts.
<b>13</b>	Enclosures are intended for indoor use primarily to provide a degree of protection against dust, spraying of water, oil, and non-corrosive coolant.	Indoor use to provide a degree of protection against lint, dust seepage, external condensation and spraying of water, oil, and non-corrosive liquids.	Indoor use; provides a degree of protection against circulating dust, lint, fibers, and flyings; seepage and spraying of non-corrosive liquids, including oils and coolants.

The preceding descriptions are not intended to be complete representations of National Electrical Manufacturers Association standards for enclosures nor those of the Electrical and Electronic Manufacturers Association of Canada.

Underwriters Laboratories Inc. (UL) shall not be responsible to anyone for the use of or reliance upon a UL Standard by anyone. UL shall not incur any obligation or liability of damages, including consequential damages, arising out of or connection with the use, interpretation of, or reliance upon a UL standard.

## Comparison of Specific Non-Hazardous Applications

### Indoor Locations

Provides a Degree of Protection Against the Following Environmental Conditions	Type Of Enclosure				Provides a Degree of Protection Against the Following Environmental Conditions	Type Of Enclosure			
	4	4X	12	13		4	4X	12	13
Incidental Contact With The Enclosed Equipment	◆	◆	◆	◆	Oil and Coolant Seepage			◆	◆
Falling Dirt	◆	◆	◆	◆	Oil or Coolant Spraying and Splashing				◆
Falling Liquids and Light Splashing	◆	◆	◆	◆	Corrosive Agents		◆		
Dust, Lint, Fibers, and Flyings*	◆	◆	◆	◆	Occasional Temporary Submersion				
Hosedown and Splashing Water	◆	◆			Occasional Prolonged Submersion				

\* These fibers and flyings are non-hazardous materials and are not considered Class III type ignitable fibers or combustible flyings. For Class III type ignitable fibers or combustible flyings see the National Electrical Code, Section 500-6(a).

# International Standards' IP Protection Classification

IEC Publication 529 Classification of Degrees of Protection by Enclosures, provides a system for specifying required enclosures of electrical equipment. IEC 529 does not specify degrees of protection against risk of explosion, or conditions such as moisture (produced, for example, by condensation), corrosive vapors, fungus, or vermin. NEMA Standards Publication 250 does test for environmental conditions such as corrosion, rust, icing, oil, and coolants. For this reason, and because the tests and evaluations for other characteristics are not identical, the IEC enclosure classification designations **CANNOT** be exactly equated with NEMA enclosure Type numbers.



The accompanying table provides a cross-reference from NEMA enclosure Type numbers to IEC enclosure classification designations. This cross-reference is an approximation based on the most current available information of enclosure test performance and is not sanctioned by NEMA, IEC, or any affiliated agency.

To use the table first find the appropriate NEMA rating along the vertical axis and then read across the horizontal axis for the corresponding IP rating. **DO NOT** use this table to convert IEC classification designations to NEMA Type numbers.

## Specification

IP 2 3

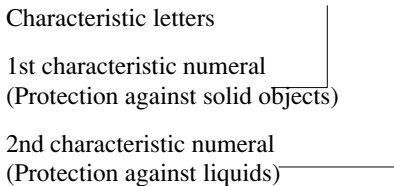

An enclosure with this designation is protected against the penetration of solid objects greater than 12mm and against spraying water.

First Numeral		Second Numeral	
IP	Tests	IP	Tests
0	No Protection	0	No Protection
1	Protected against solid objects up to 50mm, e.g. accidental touch by hands.	1	Protected against vertically falling drops of water, e.g. condensation.
2	Protected against solid objects up to 12mm, e.g. fingers.	2	Protected against direct sprays of water up to 15° from vertical.
3	Protected against solid objects over 2.5mm, e.g. tools and wires.	3	Protected against sprays to 60° from vertical.
4	Protected against solid objects over 1mm	4	Protected against water sprayed from all directions (limited ingress permitted).
5	Protected against dust (limited ingress, no harmful deposit)	5	Protected against low pressure jets of water from all directions (limited ingress permitted).
6	Totally protected against dust.	6	Protected against strong jets of water.
		7	Protected against the effects of immersion between 15cm and 1m.
			Protected against long periods of immersion under pressure.

# NEMA, UL, CSA, versus IEC Enclosure Type Cross-Reference (approximate)

(Cannot be used to convert IEC Classifications to NEMA Type Numbers)

Type Of Enclosure	IP23	IP30	IP32	IP64	IP65	IP66	IP67
4						♦	
4X						♦	
12					♦		
13					♦		

♦ Indicates compliance.

IEC 529 has no equivalents to NEMA enclosure Types 7, 8, 9, 10, or 11.

## Sources of Standards

**NEMA**  
**National Electrical Manufacturers Association**

2101 L Street Northwest  
 Washington, D.C. 20037

NEMA Standards Publication Number 250 Enclosures for Electrical Equipment (1000 Volts Maximum)

NEMA Standards Publication Number ICS6 Enclosures for Industrial Controls and Systems

**EEMAC**  
**Electrical/Electronic Manufacturers Association of Canada**

10 Carlson Court  
 Suite 500  
 Rexdale (Toronto), Ontario,  
 Canada M9W 6L2



**Underwriters Laboratories Inc.**

333 Pfingsten Road  
 Northbrook, IL 60062

UL 50 Cabinets and Boxes

UL 508 Industrial Control Equipment

UL 870 Wireways, Auxiliary Gutters and Associated Fittings



**Canadian Standards Association**

178 Rexdale Boulevard  
 Rexdale (Toronto), Ontario,  
 Canada M9W 1R3

CSA Standard C22.2 Number 94 Industrial Control Equipment for Use in Ordinary (Non-Hazardous) Locations



**International Electro-Technical Commission**

3 Rue de Varembe  
 CH-1211  
 Geneva 20, Switzerland

IEC 529 Classification of Degrees of Protection Provided by Enclosures

**ANSI**

**American National Standards Institute**

1430 Broadway  
 New York, NY 10018

ANSI Z55.1-1967 Gray Finishes for Industrial Apparatus and Equipment

**NFPA**

**National Fire Protection Association**

Batterymarch Park  
 Quincy, MA 02269

NFPA 70 National Electrical Code (1990)

# Glossary

## A

**ACCELERATION.** The time rate of change of velocity. Typical units are ft/sec/sec, meters/sec/sec, and G's (1 G = 32.17 ft/sec/sec = 9.81 m/sec/sec). Acceleration measurements are usually made with accelerometers.

**ACCELEROMETER.** Sensor whose output is directly proportional to acceleration. Most commonly use piezoelectric crystals to produce output.

**ACCURACY.** The quality of freedom from mistake or error, that is, conformity to truth, a rule or a standard; the typical closeness of a measurement result to the true value; the specified amount of error permitted or present in a physical measurement or performance setup.

**ACOUSTIC SENSITIVITY.** The parameter quantifying output signal picked up by a motion transducer when subjected to acoustic fields.

**ALIASING.** A phenomenon which can occur whenever a signal is not sampled at greater than, twice the maximum frequency component, causes high frequency signals to appear at low frequencies. Aliasing is avoided by filtering out signals greater than 1/2 the sample rate.

**ALIGNMENT.** A condition whereby the axes of machine components are either coincident, parallel or perpendicular, according to design requirements.

**AMPLITUDE.** The magnitude of dynamic motion or vibration. Amplitude is expressed in terms of peak-to-peak, zero to-peak, or RMS. For pure sine waves only, these are related as follows:

$$\text{RMS} = 0.707 \text{ times zero-to-peak;} \\ \text{peak-to-peak} = 2 \text{ times zero-to-peak.}$$

**ANALOG-TO-DIGITAL CONVERTER (A/D, ADC).** A device, or subsystem, that changes real-world analog data (as from transducers, for example) to a form compatible with digital (binary) processing.

**ANALYSIS RANGE (ANALYSIS BANDWIDTH).** (See *FREQUENCY RANGE*.)

**ANTI-ALIASING FILTER.** A low-pass filter designed to filter out frequencies higher than 1/2 the sample rate in order to prevent aliasing.

**ANTI-FRICTION BEARING.** (See *ROLLING ELEMENT BEARING*.)

**ASCII (AMERICAN STANDARD CODE FOR INFORMATION INTERCHANGE).** A seven-bit code capable of representing letters, numbers, punctuation marks, and control codes in a form acceptable to machines.

**ASYMMETRICAL SUPPORT.** Rotor support system that does not provide uniform restraint in all radial directions. This is typical for most heavy industrial machinery where stiffness in one plane may be substantially different than stiffness in the perpendicular plane. Occurs in bearings by design, or from preloads such as gravity or misalignment.

**ASYNCHRONOUS.** Vibration components that are not related to rotating speed (also referred to as nonsynchronous).

**ATTENUATION.** The reduction of a quantity such as sensitivity; i.e. through filtering or cable loading.

**ATTRIBUTE.** An individual field of a SET record or of a POINT record, a characteristic of a POINT.

**AVERAGING.** In a dynamic signal analyzer, digitally averaging several measurements to improve statistical accuracy or to reduce the level of random asynchronous components. (See *RMS*.)

**AXIAL.** In the same direction as the shaft centerline.

**AXIAL POSITION.** The average position, or change in position, of a rotor in the axial direction with respect to some fixed reference position. Ideally the reference is a known position within the thrust bearing axial clearance or float zone, and the measurement is made with a displacement transducer observing the thrust collar.

**AXIS.** The reference plane used in plotting routines. The X-axis is the frequency plane. The Y-axis is the amplitude plane.

## B

**BACKGROUND NOISE.** The total of all noise when no signal is input into the amplifier. (See *BROADBAND NOISE*.)

**BALANCE RESONANCE SPEED(s).** A rotative speed that corresponds to a natural resonance frequency.

**BALANCED CONDITION.** For rotating machinery, a condition where the shaft geometric centerline coincides with the mass centerline.

**BALANCING.** A procedure for adjusting the radial mass distribution of a rotor so that the mass centerline approaches the rotor geometric centerline.

**BALL PASS INNER RACE (BPF<sub>I</sub>).** The frequency at which the rollers pass the inner race. Indicative of a fault (crack or spall) in the inner race.

**BALL PASS OUTER RACE (BPF<sub>O</sub>).** The frequency at which the rollers pass the outer race. Indicative of a fault (crack or spall) in the outer race.

**BALL SPIN FREQUENCY (BSF).** The frequency that a roller turns within the bearing. Indicative of a problem with an individual roller.

**BANDPASS FILTER.** A filter with a single transmission band extending from lower to upper cutoff frequencies. The width of the band is determined by the separation of frequencies at which amplitude is attenuated by 3 dB (0.707).

**BAND-REJECT.** Also known as band stop and notch; a band-reject filter attenuates signal frequencies within a specified band, while passing out-of-band signal frequencies; opposite to the bandpass filter.

**BANDWIDTH.** The spacing between frequencies at which a bandpass filter attenuates the signal by 3 dB. In an analyzer, measurement bandwidth is equal to [(frequency span)/(number of filters) x (window factor)]. Window factors are: 1 for uniform, 1.5 for Hanning, and 3.63 for flat top.

**BASE STRAIN SENSITIVITY.** The parameter quantifying the unwanted output signal picked up by a motion transducer when its mounting surface is subjected to mechanical strains.

**BASILINE SPECTRUM.** A vibration spectrum taken when a machine is in good operating condition; used as a reference for monitoring and analysis.

**BAUD RATE (BIT RATE).** The rate in bits per second at which information is transmitted over a serial data link.

**BENDER BEAM ACCELEROMETER.** An accelerometer design which stresses the piezoelectric element by bending it. This design is used primarily for low frequency, high sensitivity applications. (See *COMPRESSION MODE ACCELEROMETER, SHEAR MODE ACCELEROMETER*.)

**BIAS OUTPUT VOLTAGE.** abr. BOV. Syns. Bias Voltage, Rest Voltage. The DC voltage at the output of an amplifier on which the AC motion signal is superimposed.

**BLADE PASSING FREQUENCY.** A potential vibration frequency on any bladed machine (turbine, axial compressor, fan, etc.). It is represented by the number of blades times shaft rotating frequency.

**BLOCK SIZE.** The number of samples used in a DSA to compute the Fast Fourier Transform. Also the number of samples in a DSA time display. Most DSAs use a block size of 1024. Smaller block size reduces resolution, larger block size increases resolution.

**BLOCKING CAPACITOR.** A capacitor placed in series with the input of a signal conditioning or measurement device which blocks the DC Bias Voltage but passes the AC Signal.

**BODÉ.** Rectangular coordinate plot of 1X component amplitude and phase versus running speed.

**BOW.** A shaft condition such that the geometric centerline of the shaft is not straight.

**BRINNELING (FALSE).** Impressions made by bearing rolling elements on the bearing race; typically caused by external vibration when the shaft is stationary.

**BROADBAND NOISE.** The total noise of an electronic circuit within a specified frequency bandwidth. (See *BACKGROUND NOISE*.)

**BUFFER.** 1) An isolating circuit used to avoid distortion of the input signal by the driven circuit. Often employed in data transmission when driving through long cables. 2) A temporary software storage area where data resides between time of transfer from external media and time of program-initiated I/O operations.

## C

**CAGE (RETAINER).** A component of rolling bearings which constrains the relative motion of the rolling elements circumferentially around the bearing.

**CALIBRATION.** Comparison of the performance of an item of test and measuring equipment with a certified reference standard.

**CALIBRATION CURVE.** A graphical representative of the measured transducer output or instrument readout as compared to a known input signal.

**CALIBRATOR.** Verifies that the performance of a device or instrument is within its specified limits.

**CAMPBELL DIAGRAM.** A mathematically constructed diagram used to check for coincidence of vibration sources (i.e. 1X imbalance, 2X misalignment) with rotor natural resonances. The form of the diagram is a rectangular plot of resonant frequency (Y-axis) versus excitation frequency (X-axis). Also known as an interference diagram.

**CAPACITANCE.** The ratio of the electric charge stored to the voltage applied across conductive plates separated by a dielectric material ( $C = q/V$ ).

**CARTESIAN FORMAT.** A graphical format consisting of two (2) orthogonal axes; typically, Y is the vertical axis and X is the horizontal axis. This format is used to graph the results of one variable as a function of another, e.g., vibration amplitude versus time (Trend), frequency versus amplitude (Spectrum) and 1X amplitude versus shaft rotative speed (Bodé).

**CASCADE PLOT.** (See *SPECTRAL MAP*.)

**CAVITATION.** A condition which can occur in liquid-handling machinery (e.g. centrifugal pumps) where system pressure decrease in the suction line and pump inlet lowers fluid pressure and vaporization occurs. The result is mixed flow which may produce vibration.

**CENTER FREQUENCY.** For a bandpass filter, the center of the transmission band.

**CENTERLINE POSITION.** (See *RADIAL POSITION*.)

**CHANNEL.** A transducer and the instrumentation hardware and related software required to display its output signal.

**CHARGE AMPLIFIER.** Amplifier used to convert charge mode sensor output impedance from high to low, making calibration much less dependent on cable capacitance (also, charge converter).

**CHARGE MODE ACCELEROMETER.** Any piezoelectric accelerometer that does not contain an internal amplifier and produces a high impedance charge signal.

**CHARGE SENSITIVITY.** A measure of the amount of charge produced by a charge mode accelerometer per unit of acceleration. Usually given in terms of picocoulombs per g of acceleration; written (pC/g). (See *COULOMB, VOLTAGE SENSITIVITY*.)

**CLIPPING.** Clipping is the term applied to the generally undesirable circumstance in which a signal excursion is limited in some sense by an amplifier, ADC, or other device when its full scale range is reached. Clipping may be "hard" in which the signal excursion is strictly limited at some voltage; or, it may be "soft" in which case the clipped signal continues to follow the input at some reduced gain above a certain output value.

**CLONE.** The process of exactly duplicating a SET or a POINT.

**CLOSE.** A SET or POINT is considered CLOSED if the members below it in its hierarchy are not visible. Use LEFT ARROW TO CLOSE a SET or POINT. A SET or POINT that is marked on its left by a hyphen symbol is CLOSED (not OPEN). Its members are not displayed (not visible on screen). (Also, See OPEN.)



## C

**COHERENCE.** The ratio of coherent output power between channels in a dual-channel DSA. An effective means of determining the similarity of vibration at two (2) locations, giving insight into the possibility of cause and effect relationships. The real part of a complex function. The component which is in phase with the input excitation. In frequency domain analysis, the coincident terms are the cosine terms of the "Fourier transform."

**COHERENCE FUNCTION.** Coherence is a frequency domain function generally computed to show the degree to which a linear, noise-free relationship exists between a system input and the output. Values vary between one and zero, with one being total coherence and zero being no coherence between input and output.

**COMPRESSION MODE**

**ACCELEROMETER.** An accelerometer design which stresses the piezoelectric element in the compressive direction: i.e. the electrode faces move toward and away from each other. (See *BENDER BEAM ACCELEROMETER, SHEAR MODE ACCELEROMETER.*)

**CONDITION MONITORING.** Determine of the condition of a machine by interpretation of measurements taken either periodically or continuously indicating the condition of the machine.

**CONSTANT BANDWIDTH FILTER.** A bandpass filter whose bandwidth is independent of center frequency. The filters simulated digitally in a DSA are constant bandwidth.

**CONSTANT PERCENTAGE**

**BANDWIDTH.** A bandpass filter whose bandwidth is a constant percentage of center frequency. 1/3 octave filters, including those synthesized in DSAs, are constant percentage bandwidth.

**CONTINUOUS SPECTRUM.** The type of spectrum produced from non-periodic data. The spectrum is continuous in the frequency domain (See *LINE SPECTRUM*).

**COULOMB.** symbol C. The SI unit of electric charge. The amount of charge transported by one volt of electrical potential in one second of time. One (1) picocoulomb = 10-12 coulombs.

**CPM.** Cycles per minute.

**CPS.** Cycles per second. Also referred to as Hertz (Hz).

**CREST FACTOR.** Relation between peak value and RMS value (Peak divided by RMS.)

**CRITERIA.** A means of selecting desired items from the database. Very helpful in generating reports or downloading to the MICROLOG. The types of selection criteria that can be set are POINTS IN ALARM, ENABLED POINTS, and OVERDUE POINTS that fit a selectable date range.

**CRITICAL MACHINERY.** Machines which are critical to a major part of the plant process. These machines are usually unspared.

**CRITICAL SPEED MAP.** A rectangular plot of system natural frequency (Y-axis) versus bearing or support stiffness (X-axis).

**CRITICAL SPEEDS.** In general, any rotating speed which is associated with high vibration amplitude. Often, the rotor speeds which correspond to natural frequencies of the system.

**CRYSTAL CAPACITANCE.** The electrical capacitance across the terminations of a piezoelectric crystal. Usually given in terms of picofarads; written (pF).

**CROSS AXIS SENSITIVITY.** A measure of off-axis response of velocity and acceleration transducers.

**CROSS TALK.** Interface or noise in a transducer signal or channel which has its origin in another transducer or channel. When using eddy probes, cross talk can occur when the tips of two (or more) probes are too close together, resulting in the interaction of electromagnetic fields. The effect is a noise component on each of the transducers' output signals.

**CURRENT REGULATING DIODE.** A semiconductor device which limits and regulates electrical current independent of voltage.

**CURVEFITTING.** Curvefitting is the process whereby coefficients of an arbitrary function are computed such that the evaluated function approximates the values in a given data set. A mathematical function, such as the minimum mean squared error, is used to judge the goodness of fit.

**CYCLE.** One complete sequence of values of a periodic quantity.

## D

**DAMPING.** The quality of a mechanical system that restrains the amplitude of motion with each successive cycle. Damping of shaft motion is provided by oil in bearings, seals, etc. The damping process converts mechanical energy to other forms, usually heat.

**DAMPING, CRITICAL.** The smallest amount of damping required to return the system to its equilibrium position without oscillation.

**DATABASE.** A group of SETs, subSETs, and POINTs arranged in a hierarchy that define a user's facilities (i.e., buildings, areas, machine, data gathering locations). Also a top menu bar function in PRISM<sup>2</sup>. Allows add to, change, and delete of data in the database.

**DECIBELS (dB).** A logarithmic representation of amplitude ratio, defined as 20 times the base ten logarithm of the ratio of the measured amplitude to a reference. DBV readings, for example, are referenced to 1 volt RMS. dB amplitude scales are required to display the full dynamic range of a DSA.

**DEFECT BEARING FREQUENCY.** Frequency generated as a result of a defect in a bearing.

**DEGREES OF FREEDOM.** A phrase used in mechanical vibration to describe the complexity of the system. The number of degrees of freedom is the number of independent variables describing the state of a vibrating system.

**DELAY.** In reference to filtering, refers to the time lag between the filter input and the output. Delay shows up as a frequency-dependent phase shift between output and input, and depends on the type and complexity of the filter.

**DIFFERENTIATION.** Representation in terms of time rate of change. For example, differentiating velocity yields acceleration. In a DSA, differentiation is performed by multiplication by  $j\omega$ , where  $\omega$  is frequency multiplied by  $2\pi$ . (Differentiation can also be used to convert displacement to velocity.)

**DIFFERENTIAL EXPANSION.** The measurement of the axial position of the rotor with respect to the machine casing at the opposite end of the machine from the thrust bearing. Changes in axial rotor position relative to the casing axial clearances are usually the result of thermal expansion during start-up and shutdown. Often incorporated as a measured parameter on a steam turbine.

**DIGITAL FILTER.** A filter which acts on data after it has been sampled and digitized. Often used in DSAs to provide anti-aliasing protection after internal resampling.

**DIGITAL-TO-ANALOG CONVERSION.**

The process of producing a continuous analog signal from discrete quantized levels. The result is a continuous waveform designed to match as closely as possible a previously sampled signal or a synthesized result. Usually followed by a low pass filter.

**DISCRETE FOURIER TRANSFORM.** A procedure for calculating discrete frequency components (filters or lines) from sampled time data. Since the frequency domain result is complex (i.e. real and imaginary components), the number of points is equal to half the number of samples.

**DISPLACEMENT.** The change in distance or position of an object relative to a reference.

**DISPLACEMENT SENSOR.** A transducer whose output is proportional to the distance between it and the measured object (usually the shaft).

**DOWNLOAD.** Transferring information to the Microlog from the host computer.

**DYNAMIC DATA.** Data (steady state and/or transient) which contains that part of the transducer signal representing the dynamic (e.g., vibration) characteristics of the measured variable waveform. Typical dynamic data presentations include timebase, orbit, frequency-based spectrum, polar, Bodé, cascade, and waterfall.

**DYNAMIC MOTION.** Vibratory motion of a rotor system caused by mechanisms that are active only when the rotor is turning at speeds above slow roll speed.

**DYNAMIC RANGE.** For spectrum measurements, the difference, in dB, between the overload level and the minimum detectable signal level (above the noise) within a measurement system. The minimum detectable signal of a system is ordinarily fixed by one or more of the following: noise level; low level distortion; interference; or resolution level. For transfer function measurements, the excitation, weighting and analysis approaches taken can have a significant effect on resulting dynamic range.

## E

**ECCENTRICITY, MECHANICAL.** The variation of the outer diameter of a shaft surface when referenced to the true geometric centerline of the shaft. Out-of-roundness.

**EDDY CURRENT.** Electrical current which is generated (and dissipated) in a conductive material in the presence of an electromagnetic field.

**ELECTROMAGNETIC INTERFERENCE.** abr.: EMI. The condition in which an electromagnetic field produces an unwanted signal.

**ELECTROMAGNETIC SENSITIVITY.** The parameter quantifying the unwanted output signal picked up by a motion transducer when subjected to electromagnetic fields.

**ELECTROSTATIC DISCHARGE.** abr.: ESD. A very high voltage discharge, sometimes accompanied by a spark, caused by static electrical charges across a dielectric material, such as air. This is a problem especially to electronic equipment, in hot, dry environments and plants where large rollers transport textiles or paper and build up very large amounts of charge.

**ENGINEERING UNITS.** In a DSA, refers to units that are calibrated by the user (e.g. in/sec, g's).

**ENVELOPING.** Screening technique to enhance pure repetitive elements of a signal.

**EXTERNAL SAMPLING.** In a DSA refers to control of data sampling by a multiplied tachometer signal. Provides a stationary display of vibration with changing speed.

## F

**FAST FOURIER TRANSFORM (FFT).** A computer (or microprocessor) procedure for calculating discrete frequency components from sampled time data. A special case of the discrete Fourier transform where the number of samples is constrained to a power of 2.

**FIELD.** One data item of a record. Examples of fields are first name, middle initial, last name, room number, machine ID, etc.

**FILTER.** Electronic circuitry designed to pass or reject a specific frequency band.

**FLAT TOP WINDOW.** DSA window function which provides the best amplitude accuracy for measuring discrete frequency components.

**FLUID-FILM BEARING.** A bearing which supports the shaft on a thin film of oil. The fluid-film layer may be generated by journal rotation (hydrodynamic bearing), or by externally applied pressure (hydrostatic bearing).

**FOLDING FREQUENCY.** Equal to one-half of the sampling frequency. This is the frequency above which higher signal frequencies are folded or aliased back into the analysis band.

**FORCED VIBRATION.** The oscillation of a system under the action of a forcing function. Typically forced vibration occurs at the frequency of the exciting force.

**FRAME.** Discrete set of elements (numbers) representing a time or frequency domain function. The numerical size of the element set is called the frame, block, or record size and is generally a power of 2, such as 64, 128, 256, etc. The term, frame length or block length, is used to describe the length of the element set in seconds or milliseconds and is equal to  $N/Dt$  where  $N$  is the frame size and  $Dt$  is the sampling interval.

## F

**FREE RUNNING.** A term used to describe the operation of an analyzer or processor which operates continuously at a fixed rate, not in synchronism with some external reference event. Analyzers, processors and computing systems are often thought to be operating in a triggered, block synchronous or free running mode of operation.

**FREE VIBRATION.** Vibration of a mechanical system following an initial force—typically at one or more natural frequencies.

**FREQUENCY.** The repetition rate of a periodic event, usually expressed in cycles per second (Hz), revolutions per minute (RPM), or multiples of rotational speed (orders). Orders are commonly referred to as 1X for rotational speed, 2X for twice rotational speed, etc.

**FREQUENCY COMPONENT.** The amplitude, frequency and phase characteristics of a dynamic signal.

**FREQUENCY DOMAIN.** An FFT graph (amplitude versus frequency).

**FREQUENCY RANGE.** The frequency range (bandwidth) over which a measurement is considered valid; (i.e., within manufacturer's specifications). Typical analyzers have selectable ranges. Usually refers to upper frequency limit of analysis, considering zero as the lower analysis limit (See **ZOOM ANALYSIS**).

**FREQUENCY RESPONSE.** The amplitude and phase response characteristics of a system.

**FREQUENCY RESPONSE FUNCTION.** The transfer function of a linear system expressed in the frequency domain. Commonly defined as the ratio of the Fourier transform of the system's response to the Fourier transform of the system's excitation function as magnitude and phase or real and imaginary parts. Whereas the transfer function of a linear system is, in a strict sense, defined as the ratio of the LaPlace transform of the system response to the LaPlace transform of the LaPlace transform of the system input, the frequency response function is more generally used.

**FTF.** Fundamental Train Frequency.

**FUNDAMENTAL.** The lowest frequency periodic component present in a complex spectrum. At least one complete period of a signal must be present for it to qualify as the "fundamental."

**FUNDAMENTAL TRAIN FREQUENCY (FTF).** The frequency at which the cage that contains the rollers rotates. Indicative of a fault in the cage.

## G

**g.** A standard unit of acceleration equal to one earth's gravity, at mean sea level. The acceleration of free-fall. One g equals 32.17 ft/s<sup>2</sup> (FPS) or 9.807 m/s<sup>2</sup> (MKS).

**GAIN.** The factor by which an output signal exceeds an input signal; the opposite of attenuation; usually expressed in dB.

**GEAR MESH FREQUENCY.** A potential vibration frequency on any machine that contains gears; equal to the number of teeth multiplied by the rotational frequency of the gear.

**GLOBAL BEARING DEFECT.** Relatively large damage on a bearing element.

**GROUND LOOP.** Current flow between two or more ground connections where each connection is at a slightly different potential due to the resistance of the common connection.

## H

**HANNING WINDOW.** DSA window function that provides better frequency resolution than the flat top window, but with reduced amplitude accuracy.

**HARMONIC.** Frequency component at a frequency that is an integer multiple of the fundamental frequency.

**HEAVY SPOT.** The angular location of the imbalance vector at a specific lateral location on a shaft. The heavy spot typically does not change with rotational speed.

**HERTZ (Hz).** The unit of frequency represented by cycles per second.

**HFD.** High Frequency Detection. A dynamic high frequency signal from an accelerometer which includes the accelerometer's resonant frequency. For assessing the condition of rolling element ball or roller bearings.

**HIGH-PASS FILTER.** A filter with a transmission band starting at a lower cutoff frequency and extending to (theoretically) infinite frequency.

**HIGH SPOT.** The angular location on the shaft directly under the vibration transducer at the point of closest proximity. The high spot can move with changes in shaft dynamics (e.g. from changes in speed).

## I

**IEEE 488 BUS.** An industry standard bus that defines a digital interface for programmable instrumentation; it uses a byte-serial, bit-parallel technique to handle 8-bit-wide data words.

**IMBALANCE.** Unequal radial weight distribution on a rotor system; a shaft condition such that the mass and shaft geometric centerlines do not coincide.

**INFLUENCE COEFFICIENTS.** Mathematical coefficients that describe the influence of system loading on system deflection.

**IN-PHASE (DIRECT) MOTION COMPONENT.** (In F) The Cartesian value of the 1X vibration transducer angular location. This may be expressed as:  $IN\ F = A \cos Q$ , where A is the peak to peak amplitude, and Q is the base angle of the 1X peak to peak amplitude, and Q is the phase angle of the 1X vector.

**INNER RACE.** A generally cylindrical component of rolling bearings which is positioned between the shaft and the rolling elements.

**INTEGRATED CIRCUIT PIEZOELECTRIC.** The industry standard powering scheme using a current limited voltage supply for powering internally amplified accelerometers and PVTs.

**INTEGRATION.** A process producing a result that, when differentiated, yields the original quantity. Integration of acceleration, for example, yields velocity integration is performed in a DSA by dividing by  $j\omega$ , where  $\omega$  is frequency multiplied by  $2\pi$ . (Integration is also used to convert velocity to displacement.)

**IsoRing®.** A bolt through shear mode piezoelectric sensor designs that electrically, mechanically, and thermally isolates the sensing element from the sensor housing. A registered trademark of Wilcoxon Research.

## J

**JITTER.** Abrupt and spurious shifts in time, amplitude, frequency or phase with waveforms of either a pulse or continuous nature. Can also be introduced by design as in the case of sample pulse dither.

**JOURNAL.** Specific portions of the shaft surface from which rotor applied loads are transmitted to bearing supports.

## K

**KEYPHASOR PHASE REFERENCE SENSOR.** A signal used in rotating machinery measurements, generated by a sensor observing a once-per-revolution event. The keyphasor signal is used in phase measurements for analysis and balancing. (Keyphasor is a Bently-Nevada name.)

## L

**LATERAL LOCATION.** The definition of various points along the shaft axis of rotation.

**LEAD-ZIRCONATE TITANATE.** A piezoelectric ceramic material characterized by a very high activity (sensitivity), broad temperature range, and long term stability.

**LEAKAGE.** When power from discrete frequency components extends into adjacent frequency bands.

**LINEAR RANGE.** The portion of a sensor's output voltage versus gap curve within which the slope (linearity) does not vary significantly from the nominal slope.

**LINEARITY.** The response characteristics of a linear system remain constant with input level. That is, if the response to input a is A, and the response to input b is B, then the response of a linear system to input (a + b) will be (A + B). An example of a nonlinear system is one whose response is limited by a mechanical stop, such as occurs when a bearing mount is loose.

**LINES.** Common term used to describe the filters of a DSA (e.g. 400 line analyzer).

**LINE SPECTRUM.** The discrete frequency spectrum produced by the analysis of a periodic time function. Typically presented with fixed bandwidth resolution and normally contains neither broadband noise nor transient characteristics. Not necessarily given as a line or bar display.

**LOCAL BEARING DEFECT.** Relatively small damage on a bearing element, for example, a crack in an outer ring.

**LOW-PASS FILTER.** A filter whose transmission band extends from dc to an upper cutoff frequency.

**LVDT.** Acronym for Linear Variable Differential Transformer. A contacting displacement transducer consisting of a moveable core and a stationary transformer. The core is attached to the part to be measured and the transformer is attached to a fixed reference. Often used for valve position measurements.

## M

**MEMORY LENGTH (PERIOD).** The size of storage, typically expressed in units of time for a specified sampling rate. Usually refers to the input memory section of an FFT processing system. Also, sometimes referred to as block or frame length (See **FRAME**). Defined as the sampling interval ( $\Delta t$ ) times the number of samples (N) in the data block.

**MEMORY SYNC.** A timing pulse coincident with the starting address of a fixed length, recirculating memory. Often refers to an external sync pulse used to clock the loading of a finite length memory with respect to an externally free-running process, such as during a signal averaging operation. Also used to refer to a pulse output, occurring once each time a fixed length memory is updated or recirculated.

**MODAL ANALYSIS.** The process of breaking complex vibration into its component modes of vibration, very much like frequency domain analysis breaks vibration down to component frequencies.

**MODE SHAPE.** The resultant deflected shape of a rotor at a specific rotational speed to an applied forcing function. A three-dimensional presentation of rotor lateral deflection along the shaft axis.

**MODULATION, AMPLITUDE (AM).** The process where the amplitude of a signal is varied as a function of the instantaneous value of another signal. The first signal is called the carrier, and the second signal is called the modulating signal. Amplitude modulation produces a component at the carrier frequency, with adjacent components (sidebands) at the frequency of the modulating signal.

**MODULATION, FREQUENCY (FM).** The process where the frequency of the carrier is determined by the amplitude of the modulating signal. Frequency modulation produces a component at the carrier frequency, with adjacent components (sidebands) at the frequency of the modulating signal.

**MOUNTING STUD.** A threaded screw used to rigidly attach a motion sensor to the structure under test.

**MOUNTING TORQUE.** The optimum torque applied to the sensor when mounting with a threaded stud.

**MULTIPLEXER.** A hardware device that allows multiple channels to be digitized by a single ADC. In a typical scan, the multiplexer scans the input channels sequentially, pausing only long enough between channels to allow the conversion to be completed.

## N

**NATURAL FREQUENCY.** The frequency of free vibration of a system. The frequency at which an undamped system with a single degree of freedom will oscillate upon momentary displacement from its rest position

## N

**NODAL POINT.** A point of minimum shaft deflection in a specific mode shape. May readily change location along the shaft axis due to changes in residual imbalance or other forcing function, or change in restraint such as an increased bearing clearance.

**NOISE.** Any component of a transducer output signal that does not represent the variable intended to be measured.

**NORMAL SENSITIVITY.** Syn.: Axial Sensitivity. The sensitivity of a motion sensor in the direction perpendicular to the surface of the mounting structure. (See Transverse Sensitivity.)

**NOTCH FILTER.** A band-elimination filter used to prevent the passage of specific frequencies.

**NULLING.** Vector compensation at shaft slow roll speed for 1 X electrical/mechanical runout amplitude and phase that would otherwise distort vibration measurements at higher shaft speeds.

**NYQUIST RATE.** The Nyquist rate is equal to twice the highest signal frequency and is the minimum rate at which the data can be sampled and still avoid aliasing.

## O

**OCTAVE.** The interval between two frequencies with a ratio of 2 to 1.

**OIL WHIRL/WHIP.** An unstable free vibration whereby a fluid-film bearing has insufficient unit loading. Under this condition, the shaft centerline dynamic motion is usually circular in the direction of rotation. Oil whirl occurs at the oil flow velocity within the bearing, usually 40–49% of shaft speed. Oil whip occurs when the whirl frequency coincides with (and becomes locked to) a shaft resonant frequency. (Oil whirl and whip can occur in any case where a fluid is between two cylindrical surfaces.)

**OPTICAL PICKUP.** A non-contacting transducer which detects the level of reflectivity of an observed surface. Provides a light source directed out of the tip of the pickup. When this light is reflected back to the pickup from the observed surface, a voltage is generated.

**ORBIT.** The path of the shaft centerline motion during rotation. The orbit is observed with an oscilloscope connected to X and Y-axis displacement transducers. Some dual-channel DSAs also have the ability to display orbits.

**ORDER.** A multiple of some reference frequency. An FFT spectrum plot displayed in orders will have multiples of running speed along the horizontal axis. Orders are commonly referred to as 1X for running speed, 2X for twice running speed, and so on.

**ORDER ANALYSIS.** The ability to study the amplitude changes of specific signals that are related to the rotation of the device under test. Orders are numbered by their relationship to rotational speed, such as second order = 2 times RPM; third order = 3 times RPM.

**OSCILLATION.** The variation with time of the magnitude of a quantity alternating above and below a specified reference. (See Vibration.)

**OUTER RACE.** For rolling bearings, a generally cylindrical component which is positioned between the rolling elements and the bearing housing.

**OUTPUT IMPEDANCE.** The electrical impedance as measured from the output of an electrical system. The impedance at the output of a sensor must be considerably less than that of the input of the measurement system.

**OVERLAP PROCESSING.** The processing time of an FFT computing device is the total amount of time required to calculate a desired parameter once the loading of input data memory or memories has been accomplished. If the time required to process and display the results is equal to, or less than, the time required to sample the data signals and load input memories, the processing is said to be performed on a real time basis. If the processing can be performed significantly faster than the time required to sample and load signal inputs, it is then possible to perform multiple analyses of the input signals on a segmented basis. The concept of performing a new analysis on a segment of data in which only a portion of the signal has been updated (some old data, some new data) is referred to as overlap processing.

## P

**PALOGRAM.** Waterfall plot turned 90 degrees for easier frequency specific trend identification.

**PASSBAND ANALYSIS.** Analysis of signals (information) that occur in a known, usually restricted bandwidth. Normally applies to frequency domain analysis which does not include dc. (See *BASEBAND ANALYSIS*.)

**PEAK SPECTRA.** A frequency domain measurement where, in a series of spectral measurements, the one spectrum with the highest magnitude at a specified frequency is retained.

**PEAK-TO-PEAK VALUE.** The difference between positive and negative extreme values of an electronic signal or dynamic motion. (See *AMPLITUDE*.)

**PERIOD.** The time required for a complete oscillation or for a single cycle of events. The reciprocal of frequency.

**PERIODIC IN THE WINDOW.** Term applied to a situation where the data being measured in a sampled data system is exactly periodic (repeats an integral number of times) within the frame length. Results in a leakage-free measurement in digital analysis instrumentation if a rectangular window is used. Real signals are typically not periodic in the window unless sampling is synchronized to the data periodicity.

**PERIODIC RANDOM NOISE.** A type of noise generated by digital measurement systems that satisfies the conditions for a periodic signal, yet changes with time so that devices under test respond as though excited in a random manner. When transfer function estimates are measured with this type of noise for the excitation, each individual measurement is leakage free and by ensemble averaging, the effects of system non-linearities are reduced, thus providing benefits of both pseudorandom and true random excitation.

**PERIODIC WAVEFORM.** A waveform which repeats itself over some fixed period of time.

**PERIODICITY.** The repetitive characteristic of a signal. If the period is T (sec), then this results in a discrete frequency or line spectrum with energy only at frequencies spaced at 1/T (Hz) intervals.

**PHASE.** A measurement of the timing relationship between two signals, or between a specific vibration event and a key phasor pulse.

**PHASE ANGLE.** 1) Time displacement between two currents or two voltages (or their mechanical analogs) or between a current and a voltage measured in electrical degrees where an electrical degree is 1/360 part of a complete cycle of the frequency at which the measurement is made. 2) The angle A given by  $A = \tan^{-1} x/y$ , where x and y are the real and imaginary parts of a complex number.

**PHASE REFERENCE.** A signal used in rotating machinery measurements, generated by a sensor observing a once-per-revolution event.

**PHASE RESPONSE.** The phase difference (in degrees) between the filter input and output signals as frequency varies; usually expressed as lead and lag referenced to the input.

**PHASE SPECTRUM.** Phase-frequency diagram obtained as part of the results of a Fourier transform.

**PICKET FENCE EFFECT.** In general, unless a frequency component coincides exactly with an analysis line, there will be an error in both the indicated amplitude and frequency (where the highest line is taken as representing the frequency component). This can be compensated for, provided it is known (or assumed) that one is dealing with a single stable frequency component.

**PIEZOELECTRIC.** Any material which provides a conversion between mechanical and electrical energy. For a piezoelectric crystal, if mechanical stresses are applied on two opposite faces, electrical charges appear on some other pair of faces.

**PIEZOELECTRIC ACCELEROMETER.** A sensor which employs piezoelectric materials to transduce mechanical motion into an electrical signal proportional to the acceleration.

**PIEZOELECTRIC VELOCITY TRANSDUCER.** A piezoelectric accelerometer with on board signal integration into velocity.

**POINT.** An ID established in the database. This ID names an entity which is one specific and unique data collection location. One POINT is required for each specific measurement. Both vibration and process POINTs can be established.

**POLAR PLOT.** Polar coordinate representation of the locus of the 1X, 2X, 3X, ... vector at a specific lateral shaft location with the shaft rotational speed as a parameter.

**POLARITY.** In relation to transducers, the direction of output signal change (positive or negative) caused by motion in a specific direction (toward or away from the transducer) in the sensitive axis of the transducer. Normal convention is that motion toward the transducer will produce a positive signal change.

**PRELOAD, BEARING.** The dimensionless quantity that is typically expressed as a number from zero to one where a preload of zero indicates no bearing load upon the shaft, and one indicates the maximum preload (i.e., line contact between shaft and bearing).

**PRELOAD, EXTERNAL.** Any of several mechanisms that can externally load a bearing. This includes "soft" preloads such as process fluids or gravitational forces, as well as "hard" preloads from gear contact forces, misalignment, rubs, etc.

**PROCESS POINT.** POINT type used to monitor values other than vibration. Readings can be manually entered from the keyboard collected directly from certain types of instruments. Data values can be trended by the software for comparison of these process variables with vibration data.

**PROCESSING GAIN.** In a digital Fourier analysis system, the improvement in signal-to-noise ratio between periodic components and broadband noise obtained by transformation to the frequency domain and observation in that domain. The effect is caused by the noise power being spread out over all frequencies while the discrete signal power remains constant at fixed frequencies. Doubling the number of frequency resolution lines provides 3 dB of processing gain; (i.e., the noise floor will appear to be reduced by 3 dB in each cell).

**PROM.** Programmable Read Only Memory computer chip.

**PSEUDORANDOM NOISE.** A period signal generated by repeating a data record consisting of a series of random values. This noise has a discrete spectrum with energy at frequencies spaced at 1/record length (sec).

**PYROELECTRIC EFFECT.** A property of most piezoelectric materials whereby a change in temperature produces a corresponding electrical signal.

## R

**RADIAL.** Direction perpendicular to the shaft centerline.

**RADIAL POSITION.** The average location, relative to the radial bearing centerline, of the shaft dynamic motion.

**RANDOM.** Describing a variable whose value at a particular future instant cannot be predicted exactly.

**RANDOM VIBRATION (RANDOM NOISE).** Vibration whose instantaneous value cannot be predicted with complete certainty for any given instant of time. Rather, the instantaneous values are specified only by probability distribution functions which give the probable fraction of the total time that the instantaneous values lie within a specified range.

## – NOTES –

*"Random" means not deterministic.*

*"White" means uncorrelated (flat PSD).*

*"Gaussian" describes the shape of the PDF.*

*"Noise" usually means not the signal.*

*These are all different, though related.*

## R

**REAL.** In a complex signal, the component that is in phase with the excitation. In frequency domain analysis, it is the magnitude of the cosine terms of the Fourier series, "Coincident, Co", as in CO-QUAD analyzer.

**REAL-TIME ANALYSIS.** Analysis for which, on the average, the computing associated with each sampled record can be completed in a time less than, or equal to, the record length. In digital analyzers, the functions accomplished during the computing time should be specified; (e.g., Fourier transform, calibration, normalizing by the effective filter bandwidth, averaging, display, etc.).

**REAL TIME RATE.** For a DSA, the broadest frequency span at which data is sampled continuously. Real time rate is mostly dependent on FFT processing speed.

**RELATIVE MOTION.** Vibration measured relative to a chosen reference. Displacement transducers generally measure shaft motion relative to the transducer mounting.

**REPEATABILITY.** The ability of a transducer or readout instrument to reproduce readings when the same input is applied repeatedly.

**RESOLUTION.** The smallest change in stimulus that will produce a detectable change in the instrument output.

**RESONANCE.** The condition of vibration amplitude and phase change response caused by a corresponding system sensitivity to a particular forcing frequency. A resonance is typically identified by a substantial amplitude increase, and related phase shift.

**ROLL-OFF FREQUENCY.** syn.: cutoff frequency. The frequency at which a filter attenuates a pass band gain by 3 dB.

**ROLL-OFF RATE.** Usually refers to a filter characteristic. The best straight-line fit to the slope of the "filter transmissibility characteristic" in the "transition band," usually expressed in dB per octave.

**ROLLING ELEMENT BEARING.** Bearing whose low friction qualities derive from rolling elements (balls or rollers), with little lubrication.

**ROLLOFF RATE.** Also known as "ultimate slope," filter's attenuation rate at frequencies well outside the passband. Expressed as a positive rate of change of amplitude (in dB/octave or dB/decade of frequency) for a low-pass filter; as a negative attenuation rate for a high-pass filter.

**ROOT MEAN SQUARE IRMSR.** Square root of the arithmetical average of a set of squared instantaneous values. DSAs perform RMS averaging digitally on successive vibration spectra.

**ROOT MEAN SQUARE RMS.** Square root of the arithmetic average of a set of squared instantaneous values. This can be expressed by an integral as: where  $x$  is the dependent variable,  $t$  is the independent variable and  $T$  is the period. (See **AMPLITUDE**.)

**ROTOR, FLEXIBLE.** A rotor which operates close enough to, or beyond its first bending critical speed for dynamic effects to influence rotor deformations. Rotors which cannot be classified as rigid rotors are considered to be flexible rotors.

**ROTOR, RIGID.** A rotor which operates substantially below its first bending critical speed. A rigid rotor can be brought into, and will remain in, a state of satisfactory balance at all operating speeds when balanced on any two arbitrarily selected correction planes.

**RPM SPECTRAL MAP.** A spectral map of vibration spectra versus RPM.

**RTD.** An acronym for Resistance Thermal Device; a sensor which measures temperature and change in temperature as a function of resistance.

**RUNOUT COMPENSATION.** Electronic correction of a transducer output signal for the error resulting from slow roll runout.

**RS-232C.** A de facto standard, originally introduced by the Bell System, for the transmission of data over a twisted-wire pair less than 50 feet in length; it defines pin assignments, signal levels, and so forth, for receiving and transmitting devices. Other RS-standards cover the transmission of data over distances in excess of 50 feet (RS-422; RS-485).

## S

**SAMPLING.** The process of obtaining a sequence of instantaneous values of a function at regular or intermittent intervals.

**SAMPLING RATE.** The rate, in samples per second, at which analog signals are sampled and then digitized. The inverse of the sampling interval.

**SCALE FACTOR.** The Factor by which the reading of an instrument must be multiplied in order to result in the true final value, when a corresponding (but inverse) scale factor was used initially to bring the signal amplitude within range of the instrument.

**SEISMIC.** Refers to an inertially referenced measurement or a measurement relative to free space.

**SCREENING.** Transformation of a measurement to such a form that it enhances the information about a certain defect.

**SEE™ (SPECTRAL EMITTED ENERGY).** Technology developed by SKF to measure high frequencies (250-350 kHz) associated with metal-to-metal contact in rolling element bearings.

**SEISMIC TRANSDUCER.** A transducer that is mounted on the case or housing of a machine and measures casing vibration relative to free space. Accelerometers and velocity transducers are seismic.

**SENSITIVITY.** The ratio of magnitude of an output to the magnitude of a quantity measured (for example, sensitivity of measuring voltage with an oscilloscope is specified in centimeters/volt or divisions/volt). Also, the smallest input signal to which an instrument can respond.

**SENSOR.** A transducer which senses and converts a physical phenomenon to an analog electrical signal.

**SHEAR MODE ACCELEROMETER.** An accelerometer design which stresses the piezoelectric element in the shear direction; i.e. the electrode faces move parallel to each other. (See **BENDER BEAM ACCELEROMETER**, **COMPRESSION MODE ACCELEROMETER**.)

**SHOCK LIMIT.** The maximum amount of short duration mechanical shock that a sensor can be subjected to before the possibility of permanent damage can occur. (See **MECHANICAL SHOCK**.)

**SIDEBANDS.** Additional frequencies generated by frequency modulation.

**SIDE LOBE.** A response separated in frequency from the main or desired response. Usually refers to a filter shape, particularly in digital filters that have complex structure (many notches and peaks) in the filter transition band

**SIGNAL ANALYSIS.** Process of extracting information about a signal's behavior in the time domain and/or frequency domain. Describes the entire process of filtering, sampling, digitizing, computation, and display of results in a meaningful format.

**SIGNAL CONDITIONER.** A device placed between a signal source and a readout instrument to change the signal. Examples: attenuators, preamplifiers, signal converters (for changing one electrical quantity into another, such as volts to amps or analog to digital), and filters.

**SIGNAL-TO-NOISE RATIO.** A measure of signal quality. Typically, the ratio of voltage or power of a desired signal to the undesired noise component measured in corresponding units.

**SIGNATURE.** A vibration frequency spectrum which is distinctive and special to a particular machine or component, system or subsystem at a specific point in time, under specific machine operating conditions. Used for historical comparison of mechanical condition over the operating life of the machine.

**SIGNATURE ANALYSIS.** The method whereby a physical process or device is identified in terms of the invariant frequency characteristics of the signal it generates.

**SIGNATURE ANALYZER.** Compares stored patterns (signatures) against received patterns.

**SIMULTANEOUS SAMPLE and HOLD.** In data acquisition systems, the technique of using separate sample and hold amplifiers for each channel. This allows simultaneous sampling on all channels, thereby eliminating any SKEW due to use of a multiplexer.

**SLEW RATE.** The large-signal rate-of-change of output of a filter under specific operating conditions, expressed in volts/microsecond; expresses the fastest rate at which a filter output can execute voltage level output excursions to within predicted tolerances.

**SLOW ROLL SPEED.** Low rotative speed at which dynamic motion effects from forces such as imbalance are negligible.

**SPALL.** In rolling bearings, a flake or chip of metal removed from one of the bearing races or from a rolling element. Spalling is evidence of serious bearing degradation and may be detected during normal bearing operation by observing increases in the signal amplitude of the high frequency vibrations signals.

**SPECTRAL MAP.** A three-dimensional plot of the vibration amplitude spectrum versus another variable, usually time or RPM.

**SPECTRUM.** The distribution of the amplitude of the components of a time domain signal as a function of frequency.

**SPECTRUM ANALYZER.** An instrument which displays the frequency spectrum of an input signal.

**STATIC DATA.** Data which describes the quantitative characteristics of the measured parameter. Static data can also include quantitative values describing the conditions under which the parameter was measured. For condition monitoring purposes, static data is typically presented in various forms of trend graphs and displays/lists of current values. Examples of static data include vibration amplitude, phase lag angle, frequency, vector, average shaft position, shaft rotative speed, time, date, monitor alarm and OK status.

**STEADY STATE DATA.** Data (static and/or dynamic) acquired from a machine which is on-line, under (relative) constant operating conditions (shaft rotative speed, load).

**STIFFNESS.** The spring-like quality of mechanical and hydraulic elements to elastically deform under load.

**STRAIN.** The physical deformation, deflection, or change in length resulting from stress (force per unit area).

**STRAIN GAUGE.** A transducer which reacts to changes in load, typically through changes in resistance.

**SUBHARMONIC.** Sinusoidal quantity of a frequency that is an integral submultiple of a fundamental frequency.

**SUBSYNCHRONOUS.** Component(s) of a vibration signal which has a frequency less than shaft rotative frequency.

**SYNC PULSE.** A trigger pulse which is used to synchronize two or more processes.

**SYNCHRONOUS.** The component of a vibration signal that has a frequency equal to the shaft rotative frequency (1X).

**SYNCHRONOUS TIME DOMAIN.** A dynamic amplitude vs. time graph (time domain) of data averaged in relation to a synchronous trigger pulse.

**SYSTEM IDENTIFICATION.** The process of modeling a dynamic system and experimentally determining values of parameters in the mathematical model which best describes the behavior of the system.

## T

**TEMPERATURE RANGE.** The temperature span, given by the temperature extremes, over which the sensor will perform without damage. Specifications within the temperature range may vary as a function of temperature.

**TEMPERATURE RESPONSE.** A measure of the change in a quantity, usually sensitivity, as a function of temperature.

**THERMOCOUPLE.** A temperature sensing device comprised of two dissimilar metal wires which, when thermally affected (heated or cooled), produce a proportional change in electrical potential at the point where they join.

**THRESHOLD.** The smallest change in a measured variable that will result in a measurable change in an output signal.

**THROUGH-PUT.** Amount of work performed by a system (e.g., number of batch jobs per hour processed by a computer).

## T

**THRUST POSITION.** (See *AXIAL POSITION*.)

**TIME AVERAGING.** In a DSA, averaging of time records that results in reduction of asynchronous components.

**TIMEBASE DISPLAY/PLOT.** A presentation of instantaneous amplitude of a signal as a function of time. A vibration waveform can be observed on an oscilloscope in the time domain.

**TIME DOMAIN.** A dynamic amplitude versus time graph.

**TIME LAG.** In correlation analysis one calculates an integral of the product of one signal and a temporally displaced signal. The time difference between the two signals is referred to as the time-lag.

**TIME RECORD.** In a DSA, the sampled time data converted to the frequency domain by the FFT. Most DSAs use a time record of 1024 samples.

**TIME RECORD LENGTH.** The total length of time over which a time history is observed. This total time may be broken up into several shorter data blocks.

**TIMESTAMP.** Current date assigned at time of data collection or event.

**TIME SYNCHRONOUS.** A data sampling and/or processing technique in which the beginning or ending of a data block is synchronized with an external event.

**TIME WINDOW.** The time record is often divided into segments and each segment is analyzed as a unit or frame of data. Each frame is called a block or time window. (See *WINDOW*.)

**TORQUE.** A measure of the tendency of a force to cause rotation, equal to the force multiplied by the perpendicular distance between the line of action of the force and the center of rotation.

**TORSIONAL VIBRATION.** Amplitude modulation of torque measured in degrees peak-to-peak referenced to the axis of shaft rotation.

**TRACKING FILTER.** A low-pass or bandpass filter which automatically tracks the input signal. A tracking filter is usually required for aliasing protection when data sampling is controlled externally.

**TRANSDUCER.** (See *SENSOR*.)

**TRANSIENT ANALYSIS.** When the excitation of a system is of finite duration, the analysis of the data is a transient analysis. A transient analysis can also be used to study the change from one steady-state to a second steady-state condition.

**TRANSIENT VIBRATION.** Temporarily sustained vibration of a mechanical system. It may consist of forced or free vibration or both. Typically this is associated with changes in machine operating condition such as speed, load, etc.

**TRANSVERSE SENSITIVITY.** syn.: Cross Axis Sensitivity. The parameter quantifying the unwanted output signal picked up by a motion transducer when subjected to motion perpendicular to the normal axis of operation. The transverse sensitivity is usually given in terms of the maximum percent of the normal axis sensitivity.

**TRIBOELECTRIC EFFECT.** Electrical noise caused by cable motion. When a cable is bent, the displacement of one conductor relative to the other introduces a spurious signal. Particularly problematic with high impedance electrical systems, such as charge mode accelerometers.

**TRIGGER.** Any event which can be used as a timing reference. In a DSA, a trigger can be used to initiate a measurement.

**TRIP MULTIPLIER.** That function provided in a monitor system to temporarily increase the alarm (Alert and Danger) set point values by a specific multiple. This function is normally applied by manual (operator) action during start-up to allow a machine to pass through critical speed ranges without nuisance monitor alarm indications.

**TSI.** Acronym for Turbine Supervisory Instrumentation. A TSI system is a continuous monitoring system generally used on turbogenerator sets. It can include such measurement parameters as shaft radial vibration, axial thrust position, differential expansion, case expansion, valve position, and shaft rotative speed. The TSI system consists of measurement sensors, monitors, interconnecting wiring and a microprocessor-based monitoring/data acquisition system.

**TTL (TRANSISTOR-TRANSISTOR LOGIC).** A logic family characterized by high speeds, medium power consumption, and wide usage.

## U

**UNBALANCE.** (See *IMBALANCE*.)

**UNIFORM WINDOW.** In a DSA, a window function with uniform weighting across the time record. This window does not protect against leakage, and should be used only with transient signals contained completely within the time record.

**UPLOAD.** Transferring collected data from the MICROLOG to the host computer.

## V

**VALVE POSITION.** A measurement of the position of the process inlet valves on a machine, using expressed as a percentage of the valve opening; zero percent is fully closed, 100 percent is fully open. Often incorporated as a measured parameter on steam turbines.

**VANE PASSING FREQUENCIES.** A potential vibration frequency on vaned impeller compressors, pumps, and other machines with vaned rotating elements. It is represented by the number of vanes (on an impeller or stage) times shaft rotative frequency.

**VECTOR.** A quantity which has both magnitude and direction (phase).

**VELOCITY.** The time rate of change of displacement. This is often expressed as  $V$ ,  $x$  or  $dx/dt$ ; velocity leads displacement by 90 degrees in time. Typical units for velocity are inches/second or millimeters/second, zero to peak. Velocity measurements are usually obtained with an accelerometer and integrated to velocity or a mechanically activated velocity transducer and are used to evaluate machine housing and other structural response characteristics. Electronic integration of a velocity signal yields displacement.

**VELOCITY SENSOR.** An electromechanical transducer, typically of seismic design, used for measuring bearing housing and other structural vibration. This transducer measures absolute vibration, relative to a fixed point in space.

**VIBRATION.** Magnitude of cyclic motion; may be expressed as acceleration, velocity, or displacement. Defined by frequency and timebase components.

**VIBRATION LIMIT.** The maximum amount of vibration that a sensor can be subjected to before the possibility of permanent damage can occur.

## W

**WATERFALL PLOT.** (See *SPECTRAL MAP*.)

**WAVEFORM.** A presentation or display of the instantaneous amplitude of a signal as a function of time. A vibration waveform can be observed on an oscilloscope in the timebase mode.

**WINDOW.** When a portion only of a record is analyzed, that portion is called a window. A window can be expressed in either the time domain or in the frequency domain, although the former is more common. To reduce the edge effects, which cause leakage, a window is often given a shape or weighting function. A window in the time domain is represented by a multiplication and, hence, is a convolution in the frequency domain. A convolution can be thought of as a smoothing function. This smoothing can be represented by an effective filter shape of the window; energy at a frequency in the original data will appear at other frequencies as given by the filter shape. Since time domain windows can be represented as a smoothing function in the frequency domain, the time domain windowing can be accomplished directly in the frequency domain.

## Z

**ZERO TO PEAK VALUE.** One-half of the peak to peak value. (See *AMPLITUDE*.)

**ZOOM.** Feature to magnify portions of a selected spectrum plot for more detailed examination.

**ZOOM ANALYSIS.** A zoom analysis is a technique for examining the frequency content of a signal with a fine resolution over a relatively narrow band of frequencies. The technique basically takes a band of frequencies and translates them to a lower band of frequencies, where the signals can be decimated to reduce the sample size. A standard analyzer can then be used to analyze the data.

## – NOTE –

*That the increased resolution of this technique requires a corresponding increase in the time record length. The sample rate is decreased by decimation, to reduce the number of samples in the time window, only after the demodulation.*

Trademarks used in this publication.

RYTON® is a registered trademark of Phillips Chemical Company.

TEFLON® is a registered trademark of DuPont.

UL® is a registered trademark of Underwriters Laboratories Inc.

CSA® is a registered trademark of Canadian Standards Association.

National Electric Code® is a registered trademark of National Fire Protection Association.



# SKF Condition Monitoring



*Although care has been taken to assure the accuracy of the data compiled in this publication, SKF does not assume any liability for errors or omissions. SKF reserves the right to alter any part of this publication without prior notice.*

*SKF is a registered trademark of SKF USA Inc.*

CM2004 (Revised 6-00) Copyright © 2000 by SKF Condition Monitoring, Inc. ALL RIGHTS RESERVED

## SKF Condition Monitoring Area Centers

**North and South America**  
4141 Ruffin Road  
San Diego, California 92123 USA  
Telephone (858) 496-3400  
FAX (858) 496-3531  
**Web: [www.skfcm.com](http://www.skfcm.com)**

**Europe, Middle East, Africa**  
Postbus 2091  
5300 CB Zaltbommel  
The Netherlands  
Telephone (+31) 418-681818  
FAX (+31) 418-681800

**Asia, Pacific**  
Kawasan Perindustrian Nilai  
P. O. Box 26, 71807 Nilai  
Negeri Sembilan Darul Khusus, Malaysia  
Telephone (+60) 6-799-2713  
FAX (+60) 6-799-2407

## Your SKF Condition Monitoring Representative: