

SKF Machine Condition Transmitter (MCT) CMSS500(A) Series

User Manual Part No. 32031400-EN
Revision C

User Manual

Copyright© 2007
by SKF Reliability Systems
All rights reserved.
5271 Viewridge Court
San Diego, CA 92123-1841 USA
Telephone: (858) 496-3400
Fax: (858) 496-3531
Customer Service: 1-800-523-7514



SKF Reliability Systems

5271 Viewridge Court
San Diego, California 92123 USA
Telephone (858) 496-3400
FAX (858) 496-3531

For technical support, contact:
TSG-Americas@skf.com
or
TSG-EMEA@skf.com for customers in EMEA region
(Europe, Middle East, and Africa)

Visit us at our web site:
www.skf.com/cm

SKF Patents include: #US05854553, #US05845230, #US06489884,
#US05679900, #US04768380, #US06199422, #US05992237,
#US06202491, #US06513386, #US06275781, #US06633822,
#US06006164, #US2003_0178515A1, #US6,789,025, #US6,789,360,
#WO_03_048714A1

® SKF is a registered trademark of the SKF Group

010207jj

**SKF Reliability Systems
Limited Warranty**

WARRANTY

Subject to the terms and conditions contained herein, SKF warrants to the Buyer that for the warranty period indicated below the products sold by SKF that are listed below (the "Products"), when properly installed, maintained and operated, will be free from defects in material and workmanship and shall be fit for the ordinary purposes for which the Products are designed.

BUYER'S LIMITED REMEDIES

This limited warranty defines SKF's sole and exclusive liability and Buyer's sole and exclusive remedy for any claim arising out of, or related to, any alleged deficiency in any Product sold by SKF, even if such claim is based on tort (including negligence or strict liability), breach of contract, or any other legal theory.

If the Product does not conform to this limited warranty, Buyer must notify SKF or SKF's authorized service representative within thirty (30) days of discovery of the nonconformity; provided, however, that SKF shall not be liable for any claim for which notice is received by SKF more than thirty (30) days following the expiration of the applicable warranty period for the Product. Upon receipt of timely notification from Buyer, SKF may, at its sole option, modify, repair, replace the Product, or reimburse Buyer for any payment made by Buyer to SKF for the purchase price of the Product, with such reimbursement being pro rated over the warranty period.

WARRANTY PERIOD

Except as expressly provided below, the warranty period for each Product shall commence on the date the Product is shipped by SKF to Buyer.

90-DAY WARRANTY

Products warranted for ninety (90) days by SKF are as follows: cable assemblies, MARLIN(r) QuickConnect (MQC), magnetic temperature probes, and all refurbished equipment.

ONE-YEAR WARRANTY

Products warranted for one (1) year by SKF are as follows: all Microlog(r) products and accessories, all MARLIN(r) data managers (MDM), all MARLIN(r) Condition Detectors (MCD), all Multilog Condition Monitoring Units (CMU), Multilog Local Monitoring Units (LMU), all Vibration PenPlus, all transmitters, all SKF software, all Monitor Interface Modules (MIM), all Machine Condition Transmitters (MCT), MicroVibe P and Custom Products with the prefix of CMCP (with the exception of any consumable or expendable items).

TWO-YEAR WARRANTY

Products warranted for two (2) years by SKF are as follows:

All standard Eddy Probes, Eddy Probe Drivers, and Eddy Probe Extension Cables, all standard seismic sensors (accelerometers and velocity transducers), and all M800A and VM600 Machinery Monitoring Systems.

For all On-Line Systems that have satisfied Criteria 1 and 2 below, the warranty period shall be either thirty (30) months from the date the On-Line System is shipped by SKF to Buyer, two (2) years from the date the On-Line System is installed and commissioned by SKF, or two (2) years from the date on which the installation of the On-Line System has been audited and commissioned by SKF or its authorized service representative, whichever period ends first.

Criteria 1.

Devices used with a Multilog Condition Monitoring Unit (CMU), Multilog Local Monitoring Unit (LMU), including, but not limited to, the sensing device, the interconnect cabling, junction boxes, if any, and the communications interface, must consist only of SKF-supplied or SKF-approved devices and/or components. The computer provided by Buyer must meet the requirements stipulated by SKF.

Criteria 2.

SKF or its authorized service representative has installed the On-Line System or has audited the installation and commissioned the On-Line System.

"On-Line Systems" are defined as systems consisting of Multilog Condition Monitoring Unit(s) (CMU), Multilog Local Monitoring Unit(s) (LMU), and any sensing or input devices, the interconnect cabling between the sensing or input devices and the Multilog Condition Monitoring Unit(s) (CMU), Multilog Local Monitoring Unit(s) (LMU), and the cabling between the Multilog Condition Monitoring Unit (CMU), Multilog Local Monitoring Unit (LMU) and the proprietary SKF communications interface with the host computer.

OTHER SKF PRODUCTS

Any SKF product supplied hereunder but not covered by this limited warranty shall be either covered by the applicable SKF limited warranty then in place for such product or, if no such warranty exists, shall be covered by the 90-day warranty stated above.

THIRD PARTY PRODUCT WARRANTIES

For any third party products sold to Buyer by SKF, SKF will transfer to Buyer any warranties made by the applicable third party product vendor to the extent such warranties are transferable.

CONDITIONS

As a condition to SKF's warranty obligations hereunder and if requested or authorized in writing by SKF, Buyer shall forward to SKF any Product claimed by Buyer as being defective. Buyer shall prepay all transportation charges to SKF's factory or authorized service center. SKF will bear the cost of shipping any replacement Products to Buyer. Buyer agrees to pay SKF's invoice for the then-current price of any replacement Product furnished to Buyer by SKF, if the Product that was replaced is later determined by SKF to conform to this limited warranty.

SKF shall not be obligated under this limited warranty or otherwise for normal wear and tear or for any Product which, following shipment and any installation by SKF (if required by the contract with the Buyer), has, in SKF's sole judgment, been subjected to accident, abuse, misapplication, improper mounting or remounting, improper lubrication, improper repair or alteration, or maintenance, neglect, excessive operating conditions or for defects caused by or attributable to the Buyer, including without limitation Buyer's failure to comply with any written instructions provided to Buyer by SKF.

SKF shall be free to conduct such tests, investigations and analysis of the Products returned to SKF, as it deems reasonable and proper in the exercise of its sole judgment. As a further condition to SKF's obligations hereunder, Buyer shall offer its reasonable cooperation to SKF in the course of SKF's review of any warranty claim, including, by way of example only, Buyer's providing to SKF any and all information as to service, operating history, mounting, wiring, or re-lubrication of the Product which is the subject of the Buyer's warranty claim.

EXCEPT WARRANTY OF TITLE AND FOR THE WARRANTIES EXPRESSLY SET FORTH IN HEREIN, IT IS UNDERSTOOD AND AGREED THAT: (a) SKF MAKES NO OTHER WARRANTY, REPRESENTATION OR INDEMNIFICATION, EITHER EXPRESS OR IMPLIED, INCLUDING WITHOUT LIMITATION ANY IMPLIED WARRANTY OF MERCHANTABILITY, FITNESS FOR A PARTICULAR PURPOSE, OR NON-INFRINGEMENT; (b) IN NO EVENT SHALL SKF BE LIABLE OR OBLIGATED FOR SPECIAL, EXEMPLARY, PUNITIVE, INCIDENTAL, DIRECT,

INDIRECT, GENERAL OR CONSEQUENTIAL DAMAGES (INCLUDING, BY WAY OF EXAMPLE ONLY, LOST PROFITS OR SAVINGS, LOSS OF BUSINESS OR LOSS OF USE) OR ANY OTHER LOSS, COST OR EXPENSE IN CONNECTION WITH THE PRODUCTS AND RELATED SERVICES, IF ANY, PROVIDED BY SKF, AND THIS DISCLAIMER SHALL EXTEND AS WELL TO ANY LIABILITY FOR NONPERFORMANCE CAUSED BY SKF'S GROSS OR ORDINARY NEGLIGENCE, AND IN ALL CASES REGARDLESS OF WHETHER OR NOT ANY OF THE FOREGOING WERE FORESEEABLE OR THAT SKF WAS ADVISED AS TO THE POSSIBILITY OF SUCH DAMAGES, LOSS, COST, OR EXPENSE; AND (c) NO PERSON HAS BEEN AUTHORIZED BY SKF TO MAKE ANY FURTHER OR CONTRARY INDEMNITIES, REPRESENTATIONS OR WARRANTIES ON BEHALF OF SKF. THE FOREGOING LIMITATIONS AND DISCLAIMERS OF LIABILITY SHALL BE MADE APPLICABLE TO THE SALE OF ANY PRODUCT BY SKF TO THE FURTHEST EXTENT PERMITTED BY APPLICABLE LAW.

The exclusive remedies provided in this limited warranty shall not be deemed to have failed of their essential purpose so long as SKF is willing and able to perform to the extent and in the manner prescribed in this limited warranty.

CM-F0001
(Revision N, 11-04)

Contents

Introduction	1
The MCT Transmitter	1
The MCT Monitor.....	3
Identification Label.....	6
Powering the MCT	8
CMSS500 Series Transmitters	1
Overview	1
Jumpers	7
Output.....	15
CMSS500 Series Monitor	1
Setting Monitor Alarms	1
Alert and Danger Alarm Setpoint Adjustment.....	1
Alert and Danger Alarm Delays Adjustment	4
Latching / Non-latching Alarms	6
Trip Multiply	7
Alarm Relays.....	8
Installing the Machine Condition Transmitter	1
MCT Typical Installation	1
Opening the Case.....	2
Interfacing the MCT with Other Monitoring Systems	4

Analyzing MCT Readings	6
Peak-to-Peak Measurements with the Microlog (Acceleration and Enveloped Acceleration)	7
RMS Measurements with the Microlog (Acceleration and Velocity)	8
Peak Detection in Velocity	8
CE Installation Guide	1
Overview	1
CE Installation Drawings	2
CE Installation	4
Mounting and Outline	1
CMSS500A	1
CMSS500	2
General Severity Level Guidelines	1
Vibration measured in Velocity	1
Vibration Enveloped Acceleration Measurements	4

1

Introduction

SKF Reliability Systems' Machine Condition Transmitter (MCT) modules are compact rail-mounted devices that convert part of a wide-band input signal to a signal proportional to machine vibration.

The MCT Transmitter

There are six MCT versions, the CMSS525 is an RMS acceleration transmitter, the CMSS530 is a velocity transmitter, the CMSS540 is a displacement transmitter, the CMSS545 is a position transmitter, the CMSS570 is a temperature transmitter, and the CMSS590 is an enveloped acceleration transmitter.

Output is a standard 4-20 mA current proportional to this level, within a specified full range such as 0-1 IPS RMS for velocity, or 0-10 gE for enveloped acceleration. The 4-20 mA output is suitable for a direct connection to a Programmable Logic Controller (PLC) or Distributed Control System (DCS). A BNC connector on the front of the unit provides access to the buffered transducer signal for use with portable monitoring equipment, such as the SKF Microlog[®] Series Data Collector / Analyzer.

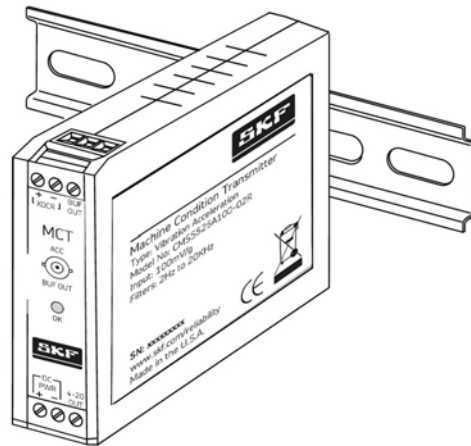

Figure 1 - 1.
The MCT - Transmitter.

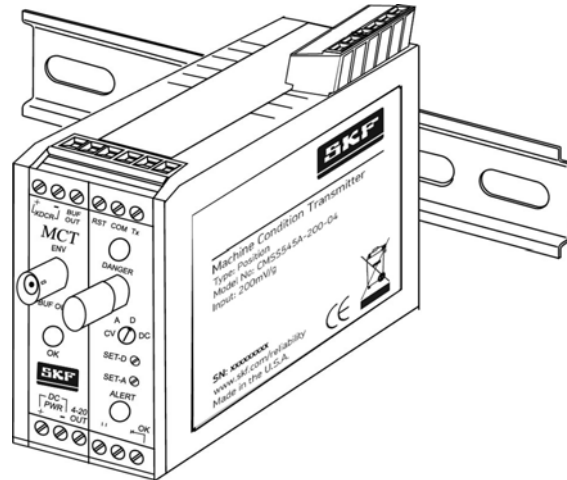

Figure 1 - 2.
The MCT - Transmitter/Monitor.

The MCT Monitor

CMSS525-	RMS Acceleration Transmitter without Monitor
CMSS525A	RMS Acceleration Transmitter with Monitor
CMSS530-	Velocity Transmitter without Monitor
CMSS530A	Velocity Transmitter with Monitor
CMSS540-	Displacement Transmitter without Monitor
CMSS540A	Displacement Transmitter with Monitor
CMSS545-	Position Transmitter without Monitor
CMSS545A	Position Transmitter with Monitor
CMSS570-	Temperature Transmitter without Monitor
CMSS570A	Temperature Transmitter with Monitor
CMSS590-	Enveloped Acceleration Transmitter without Monitor
* * CMSS590A	Enveloped Acceleration Transmitter with Monitor

Table 1 - 1.
MCT Module Configurations.

MCT modules can be ordered as stand alone Monitors by adding the suffix "A" to the basic model number (i.e., CMSS530A or CMSS590A). When ordered as a stand alone monitor, the unit includes an alarm module front panel and output relays that can be jumper configured for either latching or non-latching operation. The ALERT or DANGER LED will turn "ON" and the corresponding relay will actuate whenever overall vibration levels exceed the corresponding setpoint for more than a preset delay time (jumper selectable). The alarm module has a front panel accessible BNC connector and associated selector switch for reading the analog current vibration level (CV) or alarm setpoints (A or D) with a standard digital voltmeter. The alarm module also provides a transducer OK relay contact, and a trip multiply function (Tx). Trip multiply allows the alarm levels to be temporarily

increased by a factor of two or three to avoid false alarms, for example, during the start-up phase of a machine.

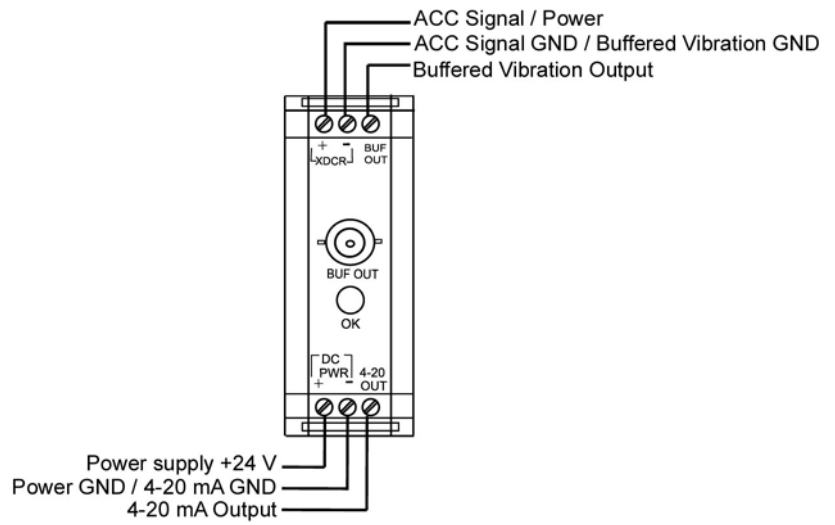

Figure 1 - 3.
MCT Transmitter General Pin Assignment.

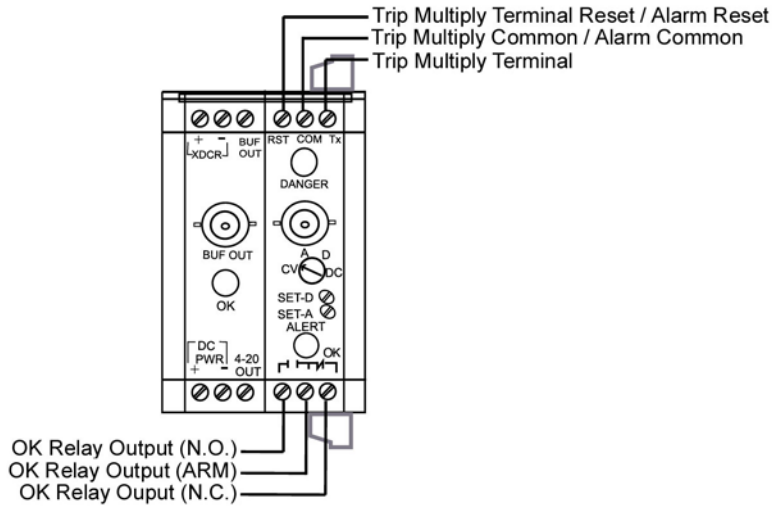

Figure 1 - 4.
MCT Transmitter / Monitor General Pin Assignment.

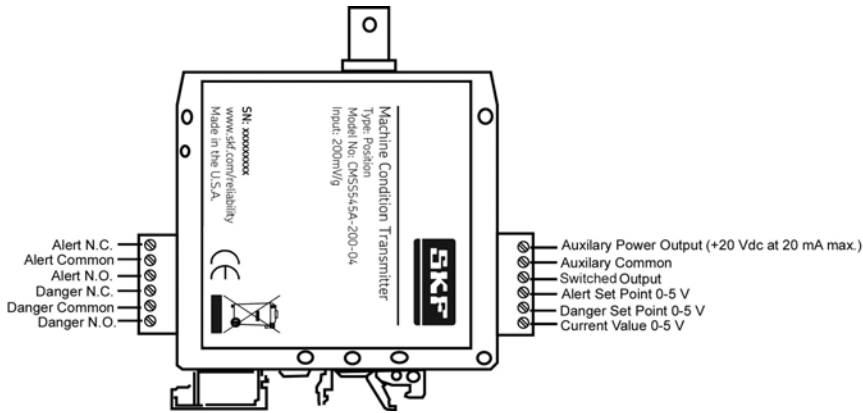

Figure 1 - 5.
MCT Transmitter / Monitor Top and Bottom Pluggable Terminals.

Both monitors and transmitters mount on standard DIN rail, either G-rail or T-rail.

For more information concerning the alarm settings, reference Setting Monitor Alarms in Chapter 3.

Identification Label

An identification label on the right side of the module provides information about the module type including a unique model number identifying data of the module's basic configuration, such as the factory configured sensor type, the measurement method and the installed filter characteristics.

Standard MCT Units

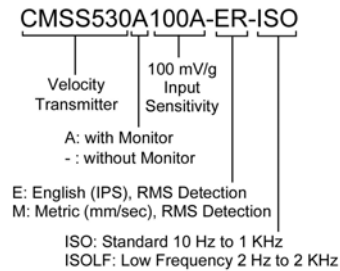
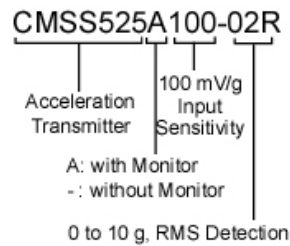

CMSS540A200-02

Displacement
Transmitter

200 mV/g
Input
Sensitivity

A: with Monitor
- : without Monitor

10 mils, Peak-to-Peak

CMSS545A200-04

Position
Transmitter

200 mV/g
Input
Sensitivity

A: with Monitor
- : without Monitor

0 - 80 mils (40-0-40) /
0 - 2.0 mm (1.0-0-1.0)

CMSS570A

Temperature
Transmitter

A: with Monitor
- : without Monitor

CMSS590A100A

Enveloped
Acceleration
Transmitter

100 mV/g
Input
Sensitivity

A: with Monitor
- : without Monitor

Each enveloped acceleration transmitter provides three band-pass filters.

Special Velocity Units

CMSS530A100V-E03P-H50L1.5

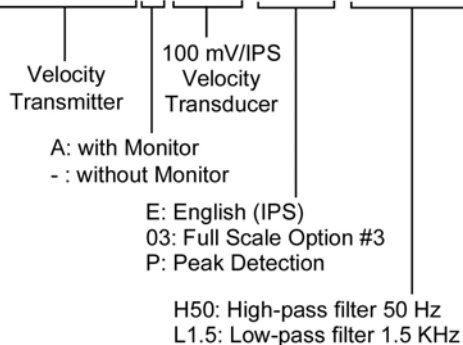

The unique serial number identifies individual transmitters and is used for warranty, quality control, and service purposes. The label also has the CSA and CE approval marks.

Powering the MCT

The MCT requires externally supplied dc power. The selected power supply should have a nominal output of +24 Vdc and be capable of supplying minimum currents noted in Table 1-2:

Model Number	Minimum Power Supply/Unit
CMSS525- CMSS530- CMSS540-	55 mA

CMSS545- CMSS570-	
CMSS525A CMSS530A CMSS540A CMSS545A CMSS570A	110 mA
CMSS590-	75 mA
CMSS590A	125 mA

Table 1 - 2.
MCT Maximum Currents.

* Average current requirements are usually lower.

A regulated power supply dedicated to the vibration monitoring system is recommended. It is also recommended that connections between the power-supply and the transmitter/monitors be made with shielded twisted instrument cable. The cable shield should float at the transmitter/monitor, and connect to ground at the power supply / system common end only. The MCT regulates dc power internally to prevent a fault on the output of one channel from affecting other channels. When power is first applied to a transmitter/monitor after connecting the transducer, a delay of approximately 30 seconds will occur before the OK LED turns "ON".

Power Supply Distribution

If more than one MCT module is installed, terminal blocks for power and ground should be used. From these terminal blocks, 24 Vdc power is distributed to each individual module. It is recommended to use individual fuse terminals for each positive supply line so a power

failure in a single MCT module will not affect the other modules.

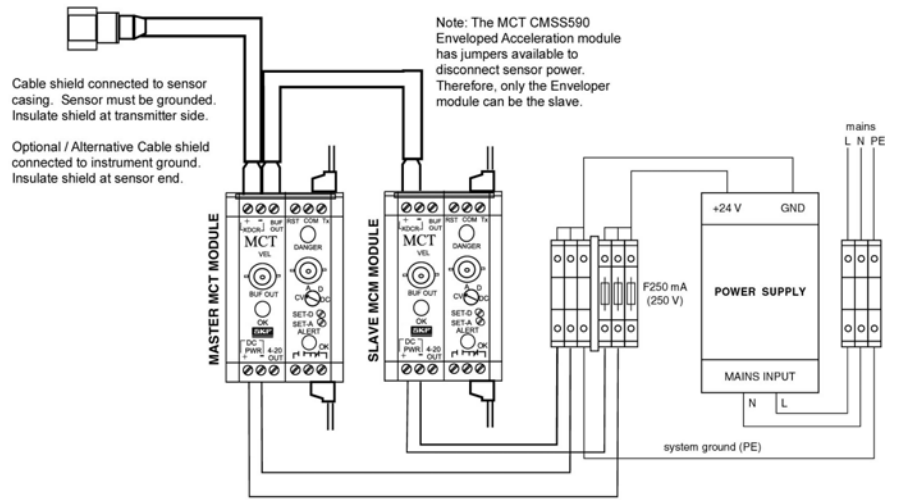

Figure 1 - 6.

Typical Power Wiring Configuration.

Grounding

When experiencing interference on the output signals due to common ground connections, it is recommended to connect the +24 V GND at the power distribution terminals to the protective ground (PE).

For CE-approved systems, it is recommended to use shielded twisted pair cables for all signal connections. Except for the sensor signal (for example, accelerometer), all shields must be connected to PE.

CMSS500 Series Transmitters

Overview

CMSS525 Acceleration Transmitter

The CMSS525 is a 4-20 mA RMS Acceleration Transmitter. It is factory configured for compatibility with a low-impedance, voltage output accelerometer. The input signal is processed to determine the overall vibration amplitude in terms of RMS acceleration (g's).

The enveloped acceleration transmitter unit always uses a 100 mV/g low-impedance, constant current powered accelerometer.

Full scale option

Range	English	Jumper
01	5 g	E2
02*	10 g	E3
03	15 g	E2, E3
04	20 g	E3, E4
05	25 g	E2, E3, E4

Table 2 - 1.
MCT Acceleration Transmitter.

* Indicates the factory preset range.

Standard filter band for the CMSS525 is from 2 Hz to 20 KHz.

CMSS530 Velocity Transmitter

The CMSS530 is a 4-20 mA Velocity Transmitter. It is factory configured for use with a low-impedance accelerometer, and can also be configured for use with a low-impedance velocity sensor, or electro-mechanical velocity sensor. The sensor input signal is processed to determine its overall vibration level in terms of either velocity (RMS or Peak).

The velocity transmitter unit is factory configured for use with one of three transducer types. The specific type is identified by four digits (for example, 100A) immediately following the basic model number on the side label. This number is the transducer sensitivity in either mV/g or mV/IPS (see Table 2-2 below).

Type I.D.	Transducer Type	Sensitivity
100A	low-impedance, constant current powered accelerometer	mV/g
100V	low-impedance, constant current powered velocity sensor	mV/IPS
500E	self-generating, electro-mechanical velocity sensor	mV/IPS

Table 2 - 7.
Identifying Transducer Type and Sensitivity.

Standard filter bands for the CMSS530 are the ISO 10 Hz to 1.0 KHz and the ISOLF 2 Hz to 2 KHz.

For example: 100A indicates the transducer is a 100 mV/g low-impedance accelerometer. Other sensitivities are available by special order.

Range:	Full Scale:		
	English	Metric	Jumper
01	.5 IPS	12.5 mm/sec	E2
02*	1.0 IPS	25 mm/sec	E3
03	1.5 IPS	37.5 mm/sec	E2 and E3
04	2.0 IPS	50 mm/sec	E3 and E4
05	2.5 IPS	62.5 mm/sec	E2, E3, E4

Table 2 - 3.
MCT Velocity Transmitter.

Full scale option for all velocity transmitter units is factory preset to 02, for 0 to 1.0 IPS or to 25.0 mm/sec if not otherwise specified in the model number.

CMSS540 Displacement Transmitter

The CMSS540 is a 4-20 mA Displacement Transmitter. It is factory configured for compatibility with an external, non-contact eddy-current probe/driver system. The displacement signal is processed to determine the overall vibration amplitude in terms of peak-to-peak displacement.

The displacement transmitter unit is factory configured for use with an external eddy-current probe-driver system. The specific displacement sensitivity is identified by four digits (for example, 200) immediately following the basic model number on the side label. This number is the transducer sensitivity in mV/mil.

For example, 200 indicates the transducer has an output sensitivity of 200 mV/mil. Other sensitivities are available by special order.

Range:	Full Scale:		
	English	Metric	Jumper
01	5 mils	127 microns	E2
02*	10 mils	254 microns	E3
03	15 mils	381 microns	E2 and E3
04	20 mils	508 microns	E3 and E4
05	25 mils	635 microns	E2, E3, E4

Table 2 - 4.
MCT Displacement Transmitter.

Standard filter band for the CMSS540 is 2 Hz to 20 KHz.

CMSS545 Position Transmitter

The CMSS545 is a 4-20 mA Position Transmitter. It is factory configured for compatibility with an external, non-contact eddy-current probe/driver system, and an external readout/monitoring system to indicate the relative axial position of a rotor within its associated bearing range. In this application, it is recommended that two independent probe/driver/transmitter channels be installed to provide redundancy, and to allow the readout/monitoring system to perform logical comparisons of the thrust readings from each channel prior to taking action on any single alarm condition.

The position transmitter unit is factory configured for use with an eddy-current probe-driver system. The specific sensitivity is identified by four digits (for example, 200) immediately following the basic model number on the

side label. This number is the transducer sensitivity in mV/mil.

For example, 200 indicates the transducer has an output sensitivity of 200 mV/mil. Other sensitivities are available by special order.

Full scale option for the position transmitter unit is factory preset to 0 to 80 mils (40-0-40) / 0 to 2.0 mm (1.0-0-1.0).

CMSS570 Temperature Transmitter

The CMSS570 is a 4-20 mA Temperature Transmitter. It is factory configured for compatibility with a solid state temperature sensor or dual output vibration / temperature sensor that provides a 10 mV/deg K output. The input signal is processed to provide temperature in Fahrenheit or Celsius.

The temperature transmitter is factory configured for use with transducers that provide a 10 mV/degK output.

Full scale option for temperature transmitter units is factory preset from 0 to 250(F / -17.8 to 121(C).

CMSS590 Enveloped Acceleration Transmitter

The CMSS590 is a Enveloped Acceleration Transmitter. It is factory configured for use with a low-impedance accelerometer. The sensor input signal is processed to determine its overall vibration level in terms of enveloped acceleration.

The enveloped acceleration transmitter unit always uses a 100 mV/g low-impedance, constant current powered accelerometer.

Range:	Full Scale:	Jumper
01*	10 gE	E8
02	30 gE	E9
03	80 gE	E10

Table 2 - 5.
MCT Enveloped Acceleration.

Full scale option for all enveloped acceleration transmitter units is factory preset to 10 gE. The Filter option is set to Filter 3 (500 Hz to 10 Hz), unless otherwise specified in the model number.

Transducer Cable

The vibration transmitter units provide power for the transducer via a nominal 4.4 mA constant current source. This is generally enough current to allow operation with transducer cables extending up to about 100 ft. Longer cables may be used, depending on the sensor and cable specifications. However, it is strongly recommended that the transmitter/monitor be mounted as close as practical to the associated transducer. This will prevent signal distortion associated with current drive limitations, and will minimize interference from external electro-magnetic noise sources (EMI). A well shielded, properly installed transducer cable is necessary to obtain reliable operation. Shielded twisted pair cables designed and pre-fitted with the proper transducer connector or sensors with integral cable, which are sold for this specific purpose, are recommended. The cable shield should be open at the transmitter end and connected to ground through the sensor casing. Alternatively, the cable shield could be

open at the transmitter end, and connected to common xdcr- terminal at the transmitter/monitor input only.

Transducer OK Circuit

The vibration transmitter units incorporate a transducer OK circuit. This feature continuously monitors the transducer bias and signal voltage. If this voltage exceeds preset limits, the 4-20 mA output current is reduced to less than 2 mA (typically 0 mA) to allow detection of the fault condition at the associated PLC or DCS system. A green OK LED on the front of the unit (normally "ON" in an OK condition) turns "OFF" to provide a local indication of the fault condition. For low-impedance, constant current powered transducers, this circuit will effectively detect open, shorted, or reversed transducer connections. When a detected fault is remedied, a delay of approximately 30 seconds occurs before the unit returns to the OK condition and the OK LED turns back "ON". A detected fault will also disable the ALERT and DANGER alarms / relays until the fault is removed and an OK condition exists.

When configured for use with an electro-mechanical transducer (E), the OK circuit will only detect an open circuit condition of the transducer / cable.

Jumpers

See Opening the Case in Chapter 4 for information on gaining access to jumpers. Changing ranges by jumper selection only will introduce an additional error of .5% typical, 2% max. For greater accuracy, the system range must be re-calibrated.

Jumper Locations





Setting	Jumper	Configuration
		Range Settings
E2 E3 E4		E2 0 to 0.5 IPS or 12.5 mm/sec Option: 01
E2 E3 E4		E3 0 to 1.0 IPS or 25.0 mm/sec / *factory preset Option: 02
E2 E3 E4		E2 and E3 0 to 1.5 IPS or 37.5 mm/sec Option: 03
E2 E3 E4		E3 and E4 0 to 2.0 IPS or 50.0 mm/sec Option: 04
E2 E3 E4		E2 and E3 and E4 0 to 2.5 IPS or 62.5 mm/sec Option: 05
		Special Filters (optional)
E1		Remove to install Filter 2
E5		Remove to install Filter 1

Table 2 - 6.
MCT Velocity and (RMS and True Peak) Displacement Options.

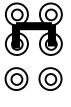
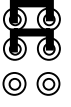
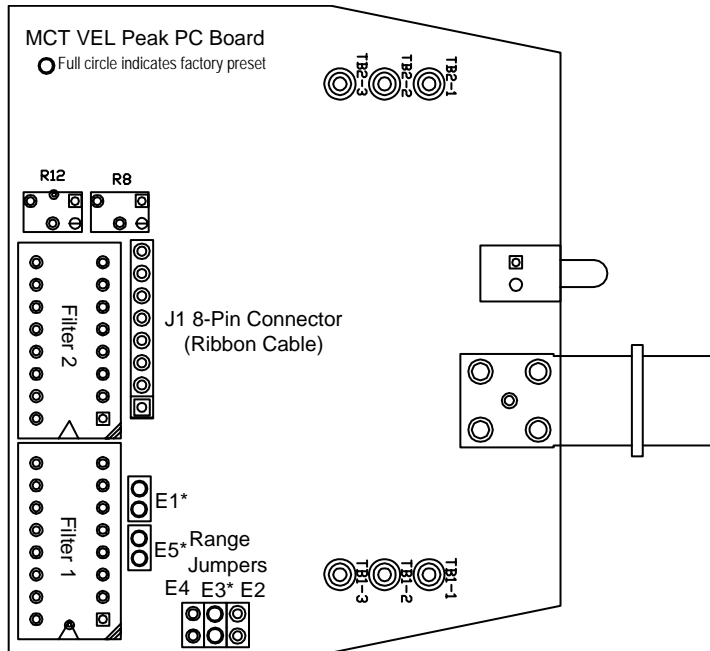

Figure 2 - 4.

MCT Velocity Peak Detection and Displacement Jumper Locations.

Range Jumpers

Range (g, RMS)	Install Jumpers
5	E2
10	E3*
15	E2, E3
20	E3, E4
25	E2, E3, E4

Table 2 - 7.
Acceleration (RMS) Range Jumpers.

Range (IPS, Peak)	Install Jumpers
0.5	E2
1.0	E3*
1.5	E2, E3
2.0	E3, E4
2.5	E2, E3, E4

Table 2 - 8.
Velocity MCT Peak Range Jumpers.

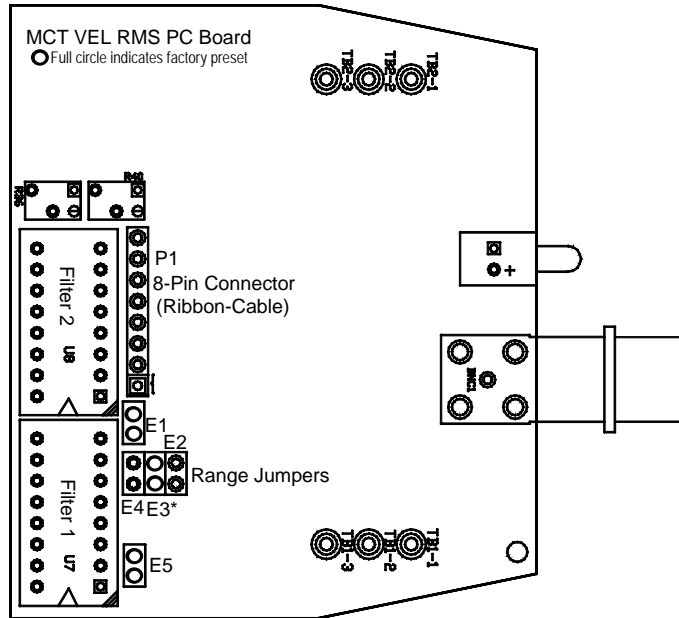

Figure 2 - 27.
MCT Velocity and Acceleration RMS Detection Jumper Locations.

Install Jumpers	Range	
	English (IPS, RMS)	Metric (mm/sec)
E2	0.5	12.5
E3*	1.0	25.0
E2, E3	1.5	37.5
E3, E4	2.0	50.0
E2, E3, E4	2.5	62.5

Table 2 - 9.
Velocity MCT RMS Range Jumpers.

Install Jumpers	Range	
	English (mils)	Metric (microns)
E2	5	127
E3*	10	254
E2, E3	15	381
E3, E4	20	508
E2, E3, E4	25	635

Table 2 - 10.
Displacement Range Jumpers.







Setting	Jumper	Configuration
		Constant Current Source
E1*		Provides constant current / *factory preset No current supply, uses buffered output as signal input
E2, E5		Selectable Filterbands ENV Filter #4 (5 kHz to 40 kHz)
E3*, E6*		ENV Filter #3 (500 Hz to 10 kHz) / *factory preset *factory preset
E4, E7		ENV Filter #2 (50 Hz to 1.0 kHz)
		Range Settings
E8*		Range 1 (0 to 10 gE) / *factory preset
E9		Range 2 (0 to 30 gE)
E10		Range 3 (0 to 80 gE)

Table 2 - 11.
Enveloped Acceleration MCT Options.

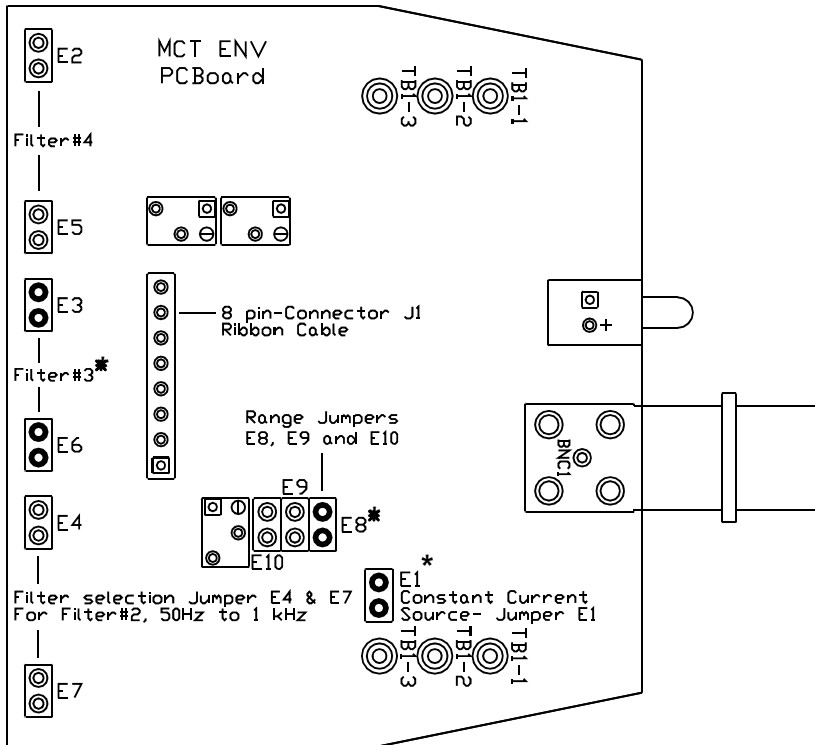

Figure 2 - 28.
Enveloped Acceleration MCT Jumper Locations.

Range Jumpers

Range (gE)	Install Jumpers
10	E8*
30	E9
80	E10

Table 2 - 12.
Enveloped Acceleration MCT Options.

CMSS590 Enveloped Acceleration Filter Selection

The enveloped acceleration transmitter is delivered with three standard band-pass filters. Table 2-13 shows the available filters for each unit.

Filter Band Number (Microlog)	BandPass Filter Frequencies (Hz)	Fmax Setting for Microlog When Compared (Hz)	Old MCM Filter for Range Reference	Jumper Setting
2	50 to 1,000	100	-44	E4 and E7
3*	500 to 10,000	1,000	-66	E3* and E6*
4	5,000 to 40,000	10,000	-88	E2 and E5

Table 2 - 13.
Integrated Enveloped Acceleration Filter Settings.

The factory preset for the enveloped acceleration transmitter module is Filter 3 (500 to 10,000Hz).

Use the following guideline to define the proper band-pass for the application.

The low frequency roll-off of the band-pass filter to eliminate rotational components is:

$$F_{min} > = 10 \times \text{RPM} / 60$$

Output

4-20 mA Output

The primary output of the transmitter/monitor is the 4-20 mA current output, which is scaled proportional to the full scale range of the unit. For example, if the range is 0 - 1 IPS peak, then 4 mA indicates a reading of 0.00 IPS, and 20 mA indicates a reading of 1.00 IPS peak. This output is intended to drive a maximum resistive load of 500 Ohms with respect to system common at the PLC / DCS input. A precision 0.25 watt, 250 Ohm resistor is the recommended load. This will convert the 4-20 mA current reading to a 1 to 5 Vdc reading for the PLC / DCS. For example, if the range is 0 to 0.5 IPS, then 1 Vdc indicates a reading of 0 IPS, and 5 Vdc indicates a reading of 0.5 IPS. A short to ground (common) on this output will not cause damage.

The relationship of the measured vibration parameter to the output current is displayed in the following equation:

$$\text{Units of Vibration} = \frac{\text{Measured Current} - 4 \text{ mA}}{16 \text{ mA}} \times \text{Full Scale Value}$$

Example Velocity

Measured Current = 12 mA; Full Scale = 1 IPS

$$\text{Converted Output Reading} = \frac{12 \text{ mA} - 4 \text{ mA}}{16 \text{ mA}} \times 1 \text{ IPS} = 0.5 \text{ IPS}$$

The relationship of the measured vibration parameter to the output voltage, when using a 250 Ohm resistor, is displayed in the following equation:

$$\text{Units of Vibration} = \frac{\text{Full Scale Value}}{4V} \times (\text{Measured Voltage} - 1)$$

Example

Measured Voltage = 3V; Full Scale 0.5 IPS

$$\text{Converted Output Reading} = \frac{0.5 \text{ IPS}}{4V} \times (3V - 1) = 0.25 \text{ IPS}$$

The relationship of the measured temperature parameter to the output current is displayed in the following equations:

$$\text{Fahrenheit} = \frac{\text{Measured Current} - 4 \text{ mA}}{16 \text{ mA}} \times \text{Full Scale Value}$$

$$\text{Celsius} = \frac{\text{Measured Current} - 6.05 \text{ mA}}{16 \text{ mA}} \times \text{Full Scale Value}$$

Example Temperature

Measured Current = 10 mA; Full Scale = 250 °F

$$\text{Converted Output Reading in Fahrenheit} = \frac{10 \text{ mA} - 4 \text{ mA}}{16 \text{ mA}} \times 250 \text{ deg F} = 93.75 \text{ deg F}$$

Measured Current = 10 mA; Full Scale = 138.8 °C (121.0 °C - (-17.8 °C))

$$\text{Converted Output Reading in Celsius} = \frac{10 \text{ mA} - 6.05 \text{ mA}}{16 \text{ mA}} \times 138.8 \text{ deg C} = 34.27 \text{ deg C}$$

Buffered Output

The MCT provides access to the buffered transducer signal using a BNC connector on the front of the unit and on a screw terminal at the top of the unit. These buffered outputs have the same sensitivities, units, and bias voltages as the transducer itself (i.e., mV/g for an accelerometer or mV/IPS for a velocity transducer). This output can be connected to portable monitoring equipment or analyzers (i.e., SKF Microlog[®] Series Data Collector / Analyzer), or can be used to check the bias output voltage (BOV) of low-impedance transducers using a digital voltmeter. The buffered output is unfiltered.

For electro-mechanical velocity transducers only: The buffered output sensitivity is scaled to 100 mV/IPS, regardless of the actual input sensitivity. For example, a 145 mV/IPS transducer will have a scaled buffered output sensitivity of 100 mV/IPS.

CMSS500 Series Monitor

- This section applies only to the Monitor units.

Setting Monitor Alarms

For a brief overview of vibration severity levels, reference the General Severity Level Guidelines appendix.

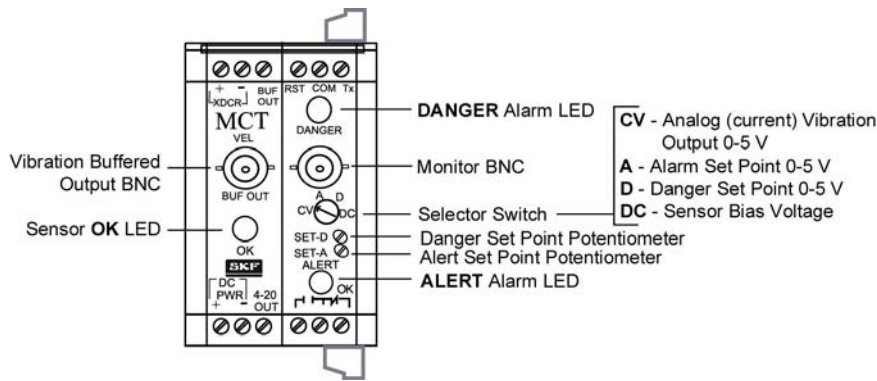

Figure 3 - 1.
MCT Front View With Monitor Options Explained.

Alert and Danger Alarm Setpoint Adjustment

ALERT and DANGER alarm setpoints can be independently set in the field by turning the front panel selector switch to the associated position (A or D) and adjusting the associated front panel potentiometer until

the correct dc voltage is measured at BNC connector located directly above the selector switch. Adjusting the setpoint requires the use of a digital voltmeter, knowledge of the transmitter's full scale range, and the desired setpoint as a percentage of the full scale range. The voltage measured at the BNC will vary between 0 Vdc and 5 Vdc, corresponding to 0 to full scale. For example, 2.5 Vdc represents 50% of full scale, 3.75 Vdc represents 75% of full scale. To calculate the required setpoint voltage, use the equation, $5(.xx)$ where $.xx$ is the desired percentage expressed as a decimal fraction of the full scale range. For example, $5(.60) = 3.00$ Vdc for a setpoint of 60% of the full scale range. Turning the potentiometer clockwise increases the setpoint voltage.

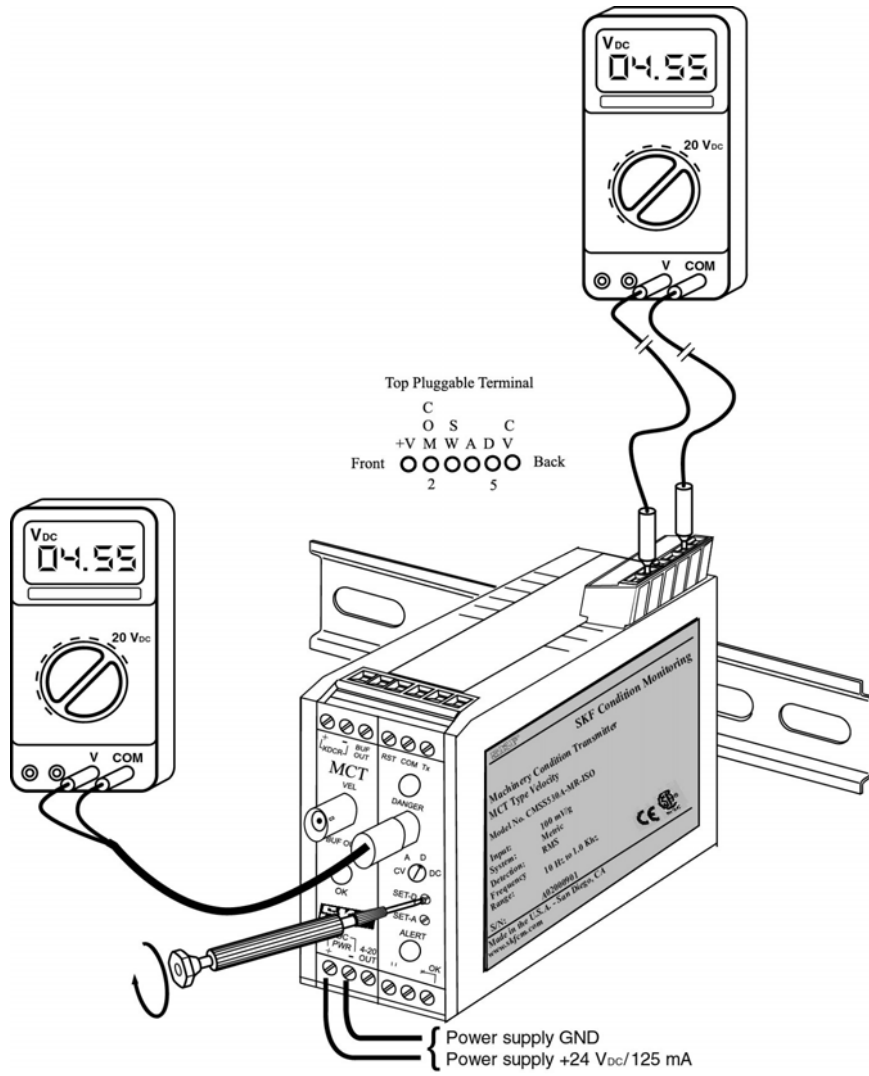

Figure 3 - 2.
Setting Alarm Levels.

Alert and Danger Alarm Delays Adjustment

The Alert and Danger alarm delays can be independently set by internal jumper selection to .1, 1, 3, 6, or 10 seconds. The purpose of the delay is to reduce nuisance alarms caused by external electrical noise and/or transient vibration events. Both the Alert and Danger delays are factory set to the 3-second position. To change the delay, open the unit and move the delay jumpers to the proper position.





Setting	Jumper	Configuration
		Alert Time Delay
E1	⊙ ⊙	0.1 sec
E2	⊙ ⊙	1 sec
E3*		3 sec / *factory preset
E4	⊙ ⊙	6 sec
E5	⊙ ⊙	10 sec
		Danger Time Delay
E6	⊙ ⊙	0.1 sec
E7	⊙ ⊙	1 sec
E8*		3 sec / *factory preset
E9	⊙ ⊙	6 sec
E10	⊙ ⊙	10 sec
		Latching / Non-latching Alarms
E11*		Open: Alert Non-latching / *factory preset Closed: Alert Latching
E12*		Open: Danger Non-latching / *factory preset Closed: Danger Latching
		Trip Multiply factor
E13*		Open: factor 2x /*factory preset Closed: factor 3x

Table 3 - 1.
Monitor Jumper Options.

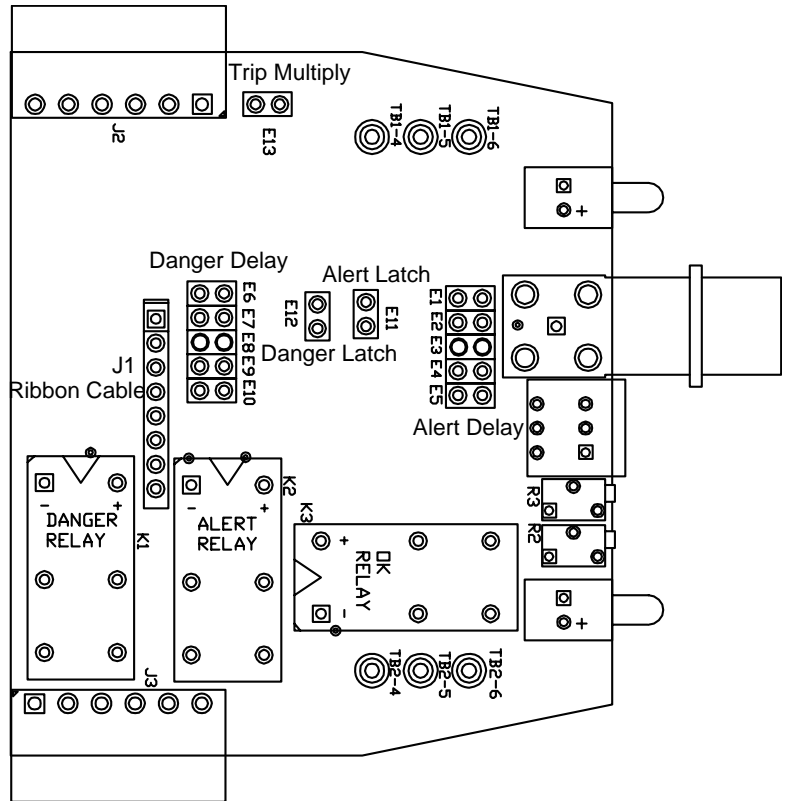

Figure 3 - 3.

Monitor Jumper Locations.

Latching / Non-latching Alarms

The Alert and Danger alarms are factory set for non-latching operation. This means that whenever the

vibration level drops below the associated setpoint for more than about 1 second, the associated relay will de-energize and the alarm LED will turn off. The alarms can also be set for latching operation by installing shunts on jumpers E11 and E12 on the Alarm module circuit board. Latched alarms may be reset by closing the RESET (RST) and COMMON (COM) contacts at the top of the unit. This may be done with an external switch, dry contact relay, or by shorting the terminals together by hand.

Important - Do not apply voltage to either the RST or COM terminals.

If several monitors are mounted together, the RST terminals may be daisy-chained together and switched to COM (system common) as a group.

Trip Multiply

The alarm module provides a trip multiply feature. This feature allows the user to temporarily double (standard) or triple (jumper selectable) the normal setpoints during periods of normal high vibration, such as start-ups. To actuate the trip multiply feature, the Tx terminal at the top of the alarm module must be closed to the adjacent COM terminal. This may be done with an external switch, dry contact relay, or by shorting the terminals together by hand.

Important - Do not apply voltage to either the Tx or COM terminals.

If several monitors are mounted together, the Tx terminals may be daisy-chained together and switched to COM (system common) as a group.

Alarm Relays

The ALERT, DANGER and OK relays are independent, single-pole-double throw relays. NO, ARM, and NC contacts are available through a plugable screw connector at the bottom of the monitor. OK relay contacts are available on fixed screw terminals at the bottom front of the alarm module. Relay contacts are rated 5 Amps at 30 Vdc or 125 Vac, resistive load. This rating includes any inrush current the load draws. For loads that are not purely resistive, the contact switching capability needs to be considered carefully in terms of this inrush current and rated accordingly.

The user is reminded to take care when applying relays.

The factory intended purpose of providing relay contacts is to operate relatively low power alarm annunciators, act as a dry or low dc voltage contact closure input to other systems, or act to actuate an appropriately sized slave relay for larger loads such as shutting down a motor.

Rated Amps	Voltage
5A	30 Vdc
5A	125 Vac
2.5A	250 Vac

Table 3 - 2.
Relay Contacts Rating.

Installing the Machine Condition Transmitter

MCT Typical Installation

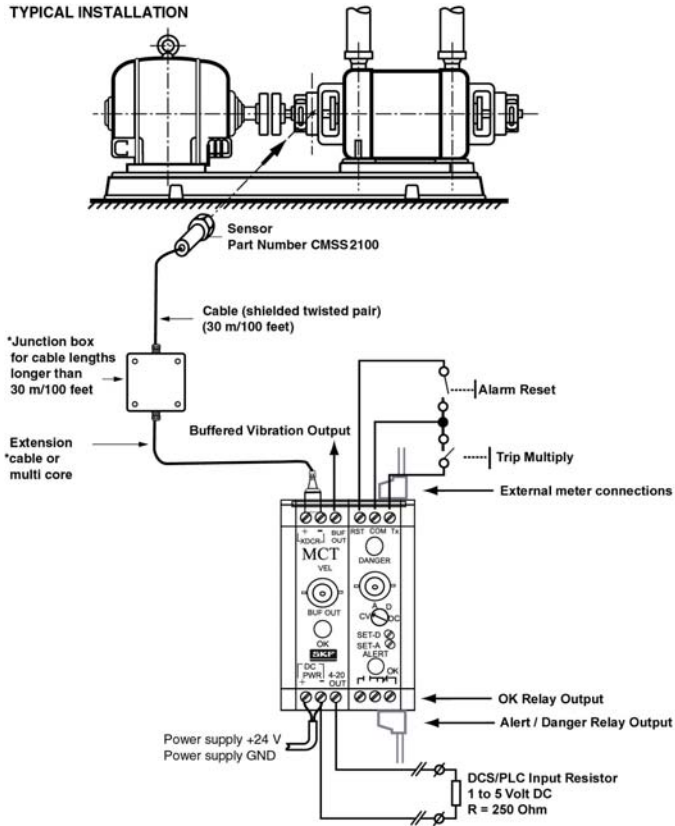

Opening the Case

Opening the MCT case is best done with a small flat-blade screwdriver. On transmitters (1 inch / 26 mm wide units), insert the tip of the screwdriver between the right side cover (as viewed from the front of the unit) and the DIN rail mounting foot at the back of the unit, as shown in Figure 4-9, and gently leverage the blade to begin separating the cover from the rest of the unit. Carefully work your way around to the front of the unit to complete removal of the cover, exposing the circuit board components.

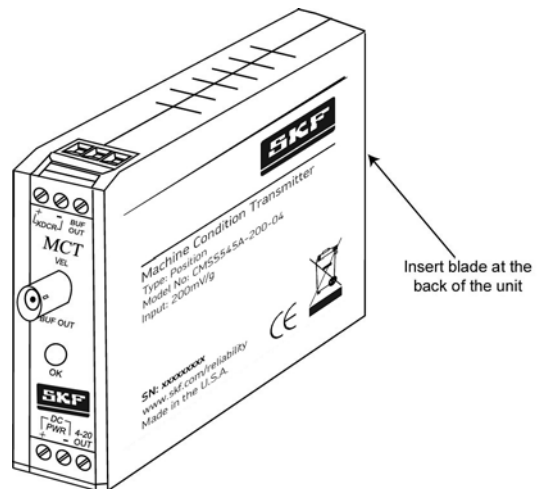

Figure 4 - 29.
Blade Insertion Point on Transmitter.

On Monitors (1.6 inch / 41 mm wide units), you must first carefully separate the two halves of the unit at the center (see Figure 4-10). The sides do not need to be removed. This is done by working the screwdriver around the

middle of the unit in the same general manner described above.

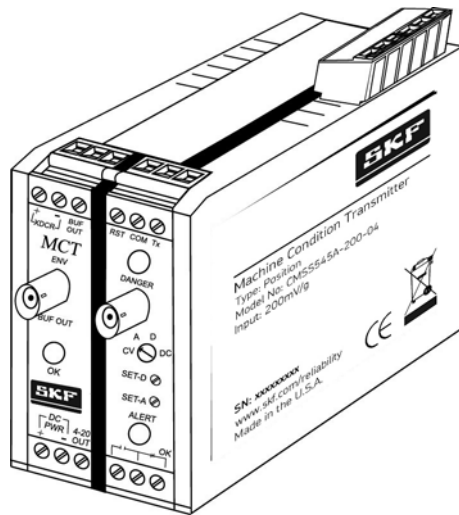

Figure 4 - 30.

Transmitter/Monitor Separated at Center.

As the two sides start to separate, you will see that a short ribbon cable inside holds them together. To remove this cable, carefully pull it away from the left hand side of the unit (as viewed from the front). The cable stays with the right hand side permanently.

Important - When reinstalling this cable, make sure it is properly connected to the mating connector, and that the bend in the cable goes towards the front panel side of the unit.

If the unit is closed with the bend towards the back, the ribbon cable can be damaged.

Also, make sure the ribbon cable connector does not catch on the relays when pressing the unit back together.

Interfacing the MCT with Other Monitoring Systems

For example, the MCT CMSS530 and CMSS590 modules interface with equipment used for process control and data analysis.

Interfacing to Process Control Systems

Interface options for process control systems are the static output 4-20 mA dc and the low power change-over relay contacts. The maximum load resistance of all connected instruments in the current loop is 500 Ohms.

Reference the section 4-20 mA Output in Chapter 2 for more information.

Interfacing to SKF Reliability Systems Products

Consider the following interface options:

- * Use SKF Reliability Systems equipment to analyze MCT module readings.
- * Use MCT modules as a front end to on-line condition monitoring equipment.

Figure 4-11 shows a combination of the above mentioned interface options.

Installing the Machine Condition Transmitter
Interfacing the MCT with Other Monitoring Systems

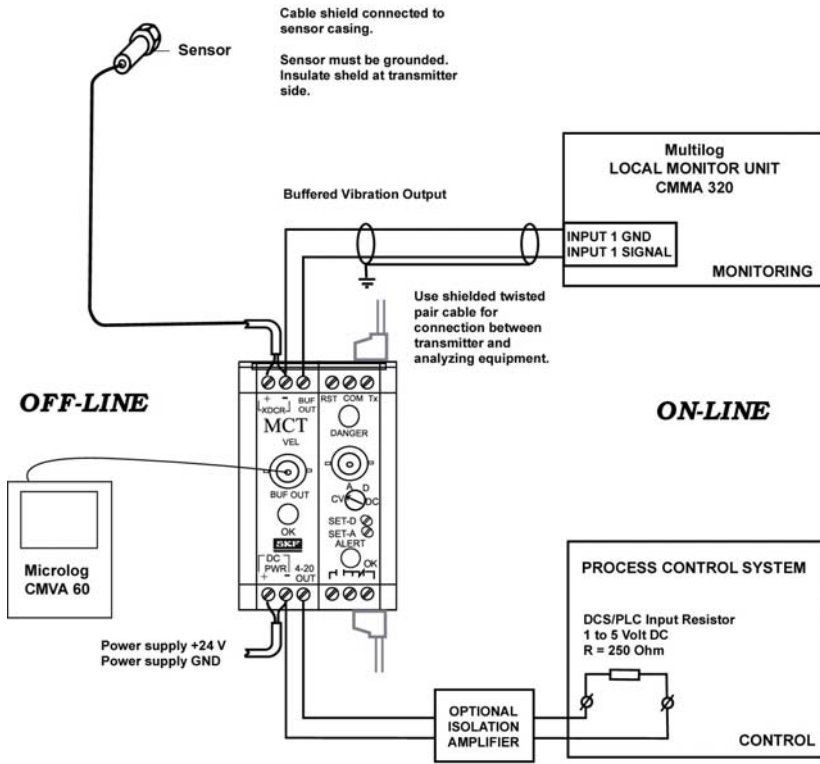

Figure 4 - 31.
MCT CMSS500 Series Interfacing.

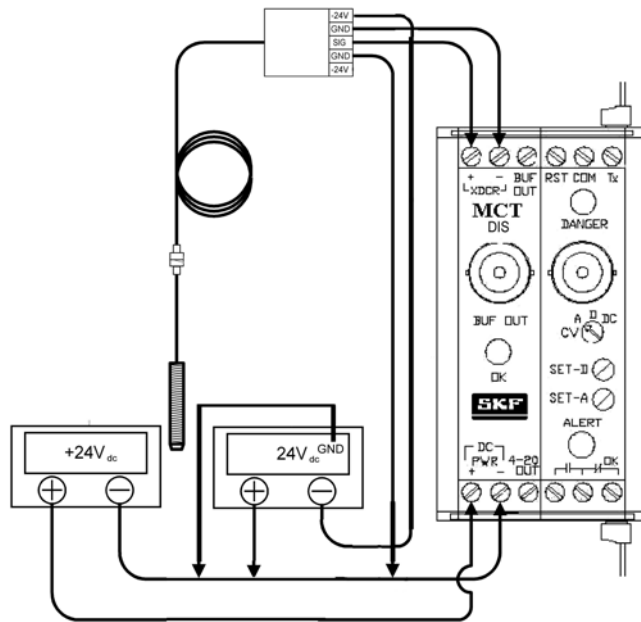

Figure 4 - 32.
MCT CMSS540 Eddy Probe Interfacing.

Analyzing MCT Readings

Unlike other SKF Reliability Systems' analyzing products that use digital signal processing, MCT modules use analog signal processing techniques, so be careful when comparing results with digital instruments. For enveloped acceleration (gE) applications, the filter ranges in the Microlog and Multilog are equal, but the filter

range of the envelope circuitry in the Vib Pen Plus is fixed between 5 kHz and 10 kHz to obtain a general bandwidth where low frequency influences, due to hand held operation, are eliminated.

Detection methods of the Microlog and Multilog are, in general, based upon detecting a maximum and minimum peak value within the whole time period of the measurement. From this peak-to-peak value, the zero peak value is calculated. The RMS value is always derived from the calculated spectrum and is not a true RMS conversion on the dynamic time signal (unlike the MCT modules).

Furthermore, MCT modules use averaging methods to prevent unwanted fluctuations. The number of averages for the Multilog and Microlog are free selectable. It is advised to select 4 to 8 averages to create a comparable total measurement time period.

Guidelines for using the Microlog as an analysis instrument in combination with the MCT modules are provided:

Peak-to-Peak Measurements with the Microlog (Acceleration and Enveloped Acceleration)

The buffered vibration output is used as an input signal to the Microlog. The selected enveloped acceleration filter setting for the Microlog must be equal to the filter choice on the enveloped acceleration transmitter. The maximum frequency must be set at twice the value of the selected low corner cut off frequency of the enveloped acceleration filter (for example, filter 500 Hz to 10 kHz results in a maximum analyzing frequency of 1 kHz).

Peak to Peak readings on the Microlog can be compared to the Peak reading of the MCT module. This difference of detection method is based upon the fact that the Microlog has an AC coupled signal processing path, while the MCT modules use a dc coupling.

RMS Measurements with the Microlog (Acceleration and Velocity)

The buffered vibration output is used as an input to the Microlog. The Microlog's frequency settings must be equal to the filter bandwidth settings of the (Velocity) MCT CMSS530 module. The detection method must be set to RMS.

Important - The MCT VEL module uses an analog filter and integrator which measure continuously.

The Multilog and Microlog calculate the RMS value from the spectrum, which is not continuously processed. This discontinuity, which is minimized by selecting the Hanning window, may cause low frequency problems which result in ski-slopes after integration. These possible ski-slope effects may have large influences on the RMS overall velocity reading.

Peak Detection in Velocity

The MCT velocity modules with peak detection provide a true peak reading, in contrary to the older MCM modules, which provided a "pseudo" peak, derived from the RMS reading. True peak detection typically results in higher values when data is collected at the same measurement

location over the same frequency range. The data can be trended and analyzed, nonetheless. If the user is more familiar with the Calculated Peak (RMS x 1.414), specify the RMS detection when ordering. Select an approximate 1.4 times higher full scale value to get the same results. For example, the older MCM has a full scale of 1 IPS and peak (pseudo) detection. An MCT velocity module with a full scale of 1.5 IPS and RMS detection will deliver the same results.

5

CE Installation Guide

Overview

For CE compliance, wiring schemes described in this CE Installation chapter must be followed. For CE installations, wiring schemes described in this chapter supersede wiring schemes described in other chapters.

Wiring scheme specific to CE installations are outlined below.

For CE installation, the MCT(s) must be installed in a metal enclosure that provides shielding to the sides, door and rear by being grounded to protective earth. The earth-ground bond must be made using a heavy gauge copper-braid cable or copper bus bar in a manner that will ensure a continuous, high-quality connection.

Signal and dc power I/O cabling for the system should be enclosed in rigid or flexible metal conduit that is bonded to earth-ground. If an ac / dc supply is included inside the enclosure, the ac input power cabling must enter the enclosure through a conduit separate from the one used for dc power and I/O signals.

If the system is to be powered by an external dc power source, the cable connecting the dc power to the system must utilize a twisted-shielded-pair cable of an appropriate gauge. The cable-shield must be connected to system ground at one end only.

The system dc ground should be connected to earth-ground at only one point in the system; typically by

connecting a system common bus-bar located in the system enclosure to the enclosure system ground bus bar.

Each sensor/transducer providing input to the system should be connected to its respective transmitter/monitor via a twisted-shielded cable assembly approved by the manufacturer for use with that specific sensor/transducer type. The sensor cable-shield must be connected to system ground at one end only. When the sensor/transducer case is mounted on an earth grounded machine casing or structural point, the cable shield may be terminated at the sensor end. Otherwise it should be terminated to earth-ground at the transmitter/monitor end via direct connection to the system ground bus bar.

Signal outputs (4-20 mA) intended for connection to remote loads, should be connected using manufacturer approved, twisted-shielded-pair cable. If the remote load is referenced to earth-ground at a location different from that of the system enclosure, a current-loop isolator may be required.

CE Installation Drawings

MCT (+24 Vdc Power Supply Installation)

- 1 System ground
 All panels from enclosure must be grounded to a system ground on enclosure.
 (Ground wires should be as short as possible).
- 2 If DC input has (2) wires (Hi/Lo), connect Hi/Lo accordingly to power supply input connector.
 If DC input has (3) wires (Hi/Lo/Earth), connect earth to enclosure system ground.
- 3 Earth Ground.
- 4 System DC Ground.
- 5 Common Bus Bar (shaded portion).

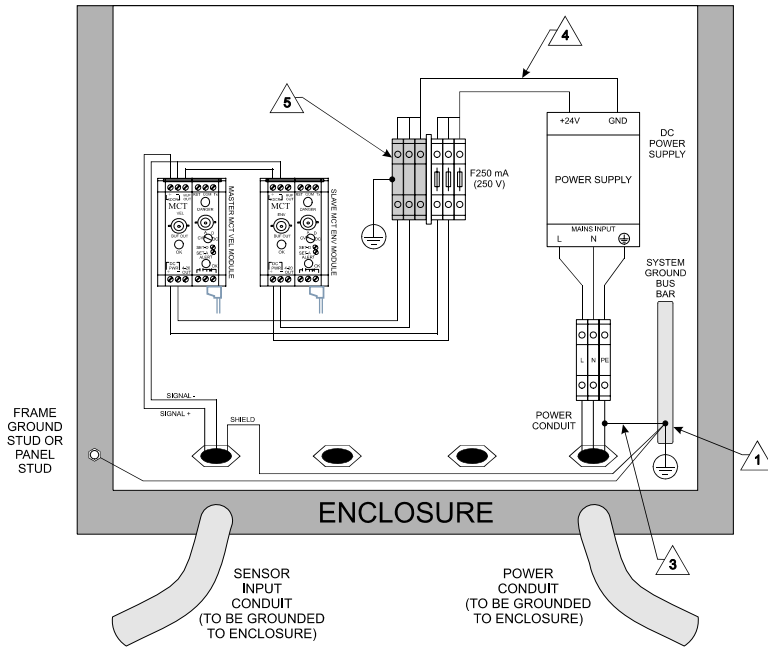

Wiring for Internally Amplified Accelerometers

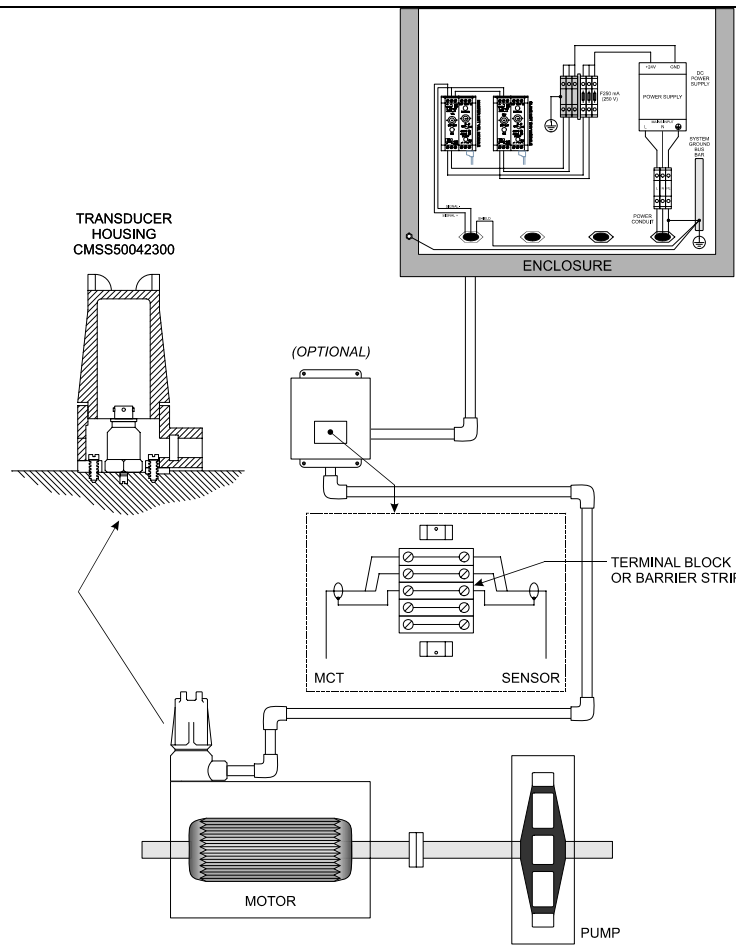

Appendix A

Mounting and Outline

CMSS500A

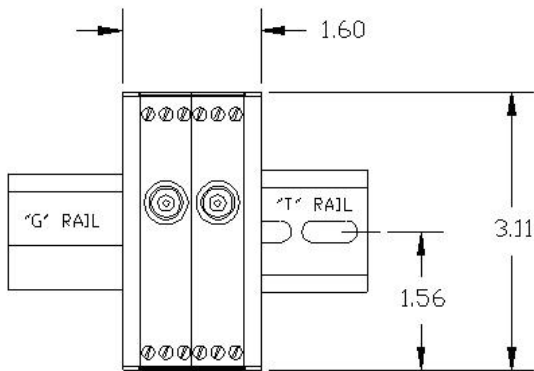

Figure A - 33.
MCT with Companion Monitor - Front View.

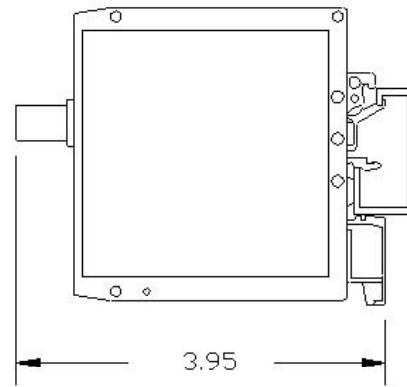

Figure A - 34.
MCT Modules - Side View.

CMSS500

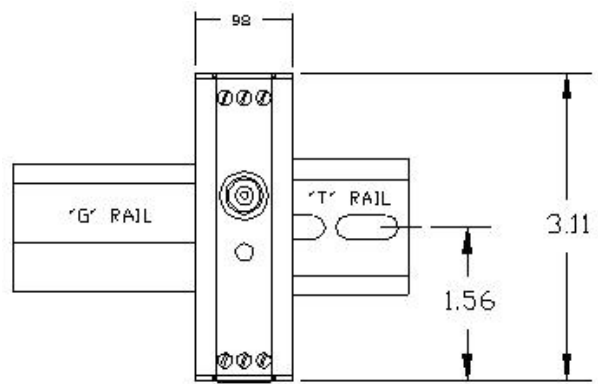

Figure A - 35.
MCT Transmitter only - Front View.

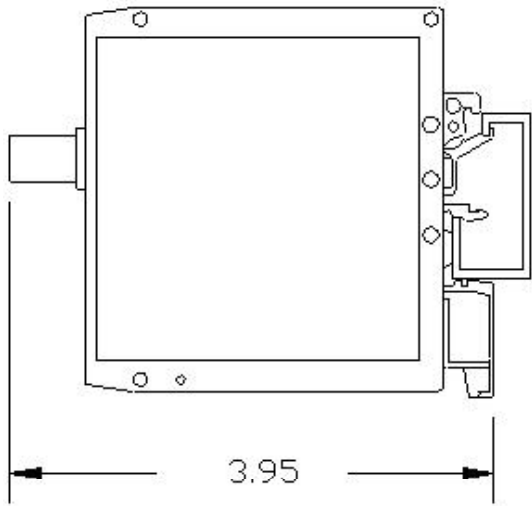

Figure A - 36.
MCT Transmitter Only - Side View.

Appendix B

General Severity Level Guidelines

When considering severity levels, be aware that standards can only provide general guidelines to determine initial alarm settings. Such guidelines should never substitute experience and good judgement. The most reliable method of determining alarm settings is to trend vibration readings over time, establish baseline values and alarm settings above baseline values.

Vibration measured in Velocity

For vibration velocity, ISO standards, such as ISO 10816, First Edition 1995, or VDI 2056 guidelines, are generally accepted. ISO 10816 with the title 'Mechanical vibration - Evaluation of machine vibration by measurements on non-rotating parts' consists of six parts. Part 1 (10816-1) determines general guidelines and is followed by the additional parts of ISO 10816, for example Part 2 (10816-2) for land-based steam turbines and generators in excess of 50 MW with normal operating speeds of 1500 RPM, 1800 RPM, 3000 RPM and 3600 RPM.

The following severity chart is in accordance with the ISO 10816-2 guidelines. For exceptions to this guideline and for more information, reference the ISO 10816-2 document.

ISO 10816-2	Steam Turbines and Generators	
Speed (RPM)	1500 or 1800	3000 or 3600
Velocity		
mm/sec RMS	Damage	occurs
11.8		
10.0		
8.5		
7.5	Restricted	Operation
5.3		
3.8	Unrestricted	Operation
2.8		
1.4	Newly	Commissioned
0.0		Machinery

Table B - 15.
 Vibration Severity Chart ISO 10816-2.

Industrial machines with nominal power above 15 kW and nominal speeds between 120 RPM and 15000 RPM when measured in position are covered by ISO 10816-3.

The machines are separated into 4 different groups:

Group 1: Large machinery and electrical machines with shaft height greater than 315 mm that are normally equipped with sleeve bearings.

Group 2: Medium-size machines and electrical machines with shaft height between 160 mm and 315 mm that are normally equipped with rolling element bearings and operate at speeds above 600 RPM.

Group 3: Pumps with multivane impellers and separate drivers with rated power above 15 kW. Machines of this group may be equipped with sleeve or rolling element bearings.

Group 4: Pumps with multivane impellers and with integrated drivers that are equipped with sleeve or rolling element bearings.

ISO 10816-3	Machinery Group 2 & 4		Machinery Group 1 & 3	
Rated Power	15 kW – 300 kW		Group 1: 300 kW – 50 MW Group 3: above 15 kW	
Velocity				
mm/sec RMS		Damage	occurs	
11.0				
7.1				
4.5		Restricted	Operation	
3.5				
2.8		Unrestricted	Operation	
2.3				
1.4				
0.7		Newly	Commissioned	Machinery
0.0				
Foundation	Rigid	Flexible	Rigid	Flexible

Table B - 16.
Vibration Severity Chart ISO 10816-3.

Vibration Enveloped Acceleration Measurements

Severity levels for machine vibration and bearing defect detection by means of the enveloping technique are needed to classify the machine condition according to standards and practical guidelines.

For enveloped acceleration in all forms, severity levels are related to speed and bearing size. The bearing size is generally related to the load capabilities of the machine. The higher the speed, the higher the energy generated by impacts as elements roll over bearing damage.

The relation: Maximum shaft speed times shaft diameter has a maximum, depending on the bearing technology.

Notice that for bigger bearings the speed is limited, and therefore, the severity levels are also limited. Carefully select the severity levels for enveloped acceleration using machine knowledge. Sensor location and sensor installation is important for successful machine monitoring. The boundaries between different states of severity conditions are less defined. Comparative and relative judgement methods are preferred above absolute judgement and the application of standards.

For creating a comparative measurement, the process control system is able to create a trend of the vibration signal. This signal can be compared against a 'baseline' overall measurement of that measurement point, with the knowledge that the machine is running under normal conditions.

In many cases, periodic measurements have been performed on equipment before a permanent monitor (such as the MCT system) is installed. The knowledge of those measurements and the machine behavior provides a good indication of effective alarm level settings.

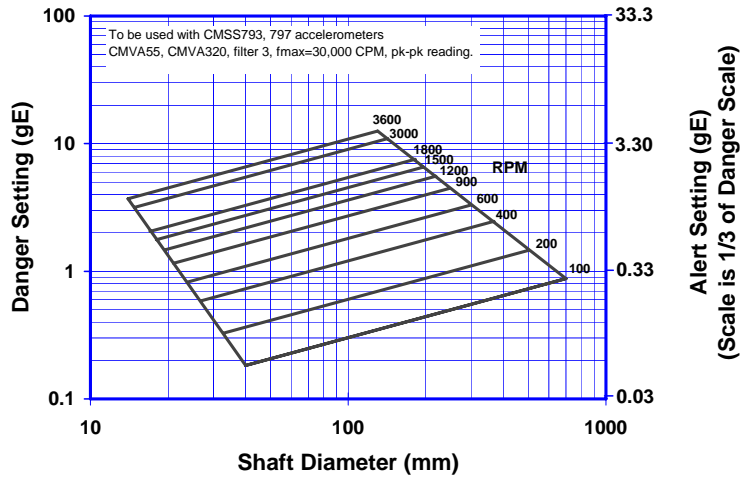

Figure B - 37.
 Enveloped Acceleration Alarm Guidelines (Fmax = 60,000 CPM).

To utilize the above chart, the following parameters must be known:

Bearing bore diameter in mm (indicates load)

Shaft speed in RPM

Assumptions for using the above chart are necessary as deviations from standardized data collection greatly affect enveloped acceleration readings. Assumptions are as follows:

Filter 3 = 500-10,000 Hz

Fmax = 60,000 CPM / 1,000 Hz

A scaling factor is required for other Fmax values. A scaling equation is provided in Part II.

Sensor = CMSS793 or CMSS797 or MCD probe

Detection = Peak to Peak

Perform measurements with the machine operating under normal conditions. For example, when the rotor and the main bearings have reached their normal steady operating temperatures and with the machine running under its normal rated condition (at rated voltage, flow, pressure, and load).

To obtain the most accurate readings, enveloped acceleration measurements require probe placement in the maximum load zone, or as close as possible to the maximum load zone within the measured bearing or gear box.

Example

Bearing bore diameter:	100 mm
Shaft speed:	1800 RPM
Fmax:	60,000 CPM

Use the chart in Figure B-1 to determine this enveloped acceleration measurement's alert and danger alarm settings:

Locate 100 mm on the shaft diameter axis.

Follow the vertical line representing 100 mm to the point where it intersects the 1800 RPM running speed line. This is your reference point.

From your reference point, follow the horizontal lines left to the danger settings axis to determine your initial danger alarm setting (7.5 gE).

From your reference point, follow the horizontal lines right to the alert settings axis to determine your initial alert alarm setting (2.5 gE).

Use the Scaling Factor chart (Figure B-2).

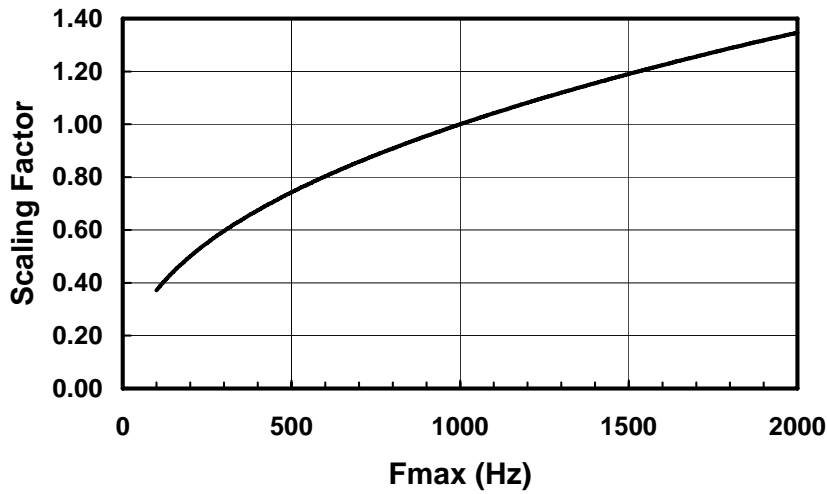

Figure B - 38.
Scaling Factor for Fmax Compensation for Enveloped Acceleration
Measurements.

The definition for an alarm condition for the enveloped acceleration transmitter module also depends on the application. Alarms can be a warning that a certain condition has occurred and that further analysis is required. Based upon those results, a decision must be made on further required actions. The MCT is then used as a monitoring device.

The alarm condition can also be used to take direct action. In this case the MCT module is fulfilling a protective task together with the process control / relay system.

The software CMSW5000 'Atlas For Windows' features a calculator for enveloped acceleration alarm settings and is based on identical assumptions.

General Severity Level Guidelines

Vibration Enveloped Acceleration Measurements

For more information please visit our website www.skfcm.com, select Support. From the Support Center Home, select Application Notes. Download CM3068.PDF from the Machine Condition Transmitters category.

Index

4

4-20 mA 1-1, 5-2
4-20 mA Output 2-14

A

Alarm Delays 3-4
Alarm Relays 3-8
Alarm Setpoints 3-1

B

band-pass filters 2-16
BNC connector 1-3, 2-15, 3-1
BOV 2-15
Buffered Output 2-15

C

CE Installation 5-1
CMSS525 1-1
CMSS530 1-1
CMSS540 1-1
CMSS545 1-1
CMSS570 1-1
CMSS590 1-1
COM terminal 3-7

D

dc power 1-9, 5-1

E

EMI 2-6

F

Filter
Enveloped Acceleration 2-16
Full scale 2-3

G

Grounding 1-11

I

ISO B-1

J

Jumper Locations 2-8

L

Latching / Non-latching Alarms 3-7

M

MCT
Installation 5-3
Microlog 1-1, 2-15

P

Peak Detection 4-8
Power Supply Distribution 1-10

R

RMS 1-1
RST terminals 3-7

T

Transducer Cable 2-6
Transducer OK Circuit 2-7
Trip multiply 1-4
Trip Multiply 3-7
Typical Power Wiring
Configuration 1-10

V

Vibration
Enveloped Acceleration B-3
Velocity B-1

